

Frank  
Tel:0086-15906695839  
Email:frank@sc-transmission.com  
Website:www.sc-transmission.com



WWW.SC-TRANSMISSION.COM

V-Belt Pulleys

## V-BELT PULLEYS

V-Belt Pulleys for Taper Bushes. . . . .	120-146
V-Belt Pulleys with Solid Hub. . . . .	147-157
Adjustable Speed V-Belt Pulleys. . . . .	158
Flat Belt Pulleys for Taper Bushes. . . . .	159

# V-Belt Pulleys

## V-belt Pulleys

in this catalogue are all manufactured according to ISO 4183 and DIN 2211 norms.

The material used for the construction of these pulleys is cast iron **GG25** and after machining all pulleys are being **PHOSPHATED**.

Each pulley is strictly **DYNAMICALLY BALANCED** with high precision dynamical balancing machining tools. Unbalanced volume will corrected accurately.

Each pulley can be used safely and reliably.

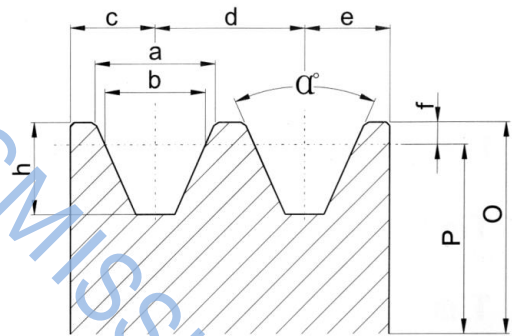

Pulley Dimensions

	a	b	c	d	e	f	h	34°	38°
<b>SPZ</b>	9.7	8.5	8	12	8	2.5	12	p<=80	p>=80
<b>SPA</b>	12.7	11	10	15	10	3.5	15	p<=118	p>=118
<b>SPB</b>	16.3	14	12.5	19	12.5	4	18	p<=190	p>=190
<b>SPC</b>	22	19	16	25	16	5	24	p<=315	p>=315

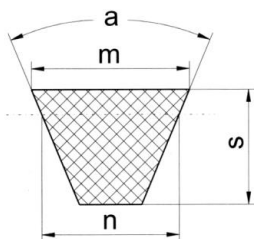

Belt Dimensions

	m	s	n
<b>SPZ</b>	9.7	8	8.5
<b>SPA</b>	12.7	10	11.0
<b>SPB</b>	16.3	13	14.0
<b>SPC</b>	22.0	18	19.0

# SPZ/1 | V-Belt Pulleys For Taper Bushes



Taper Bore

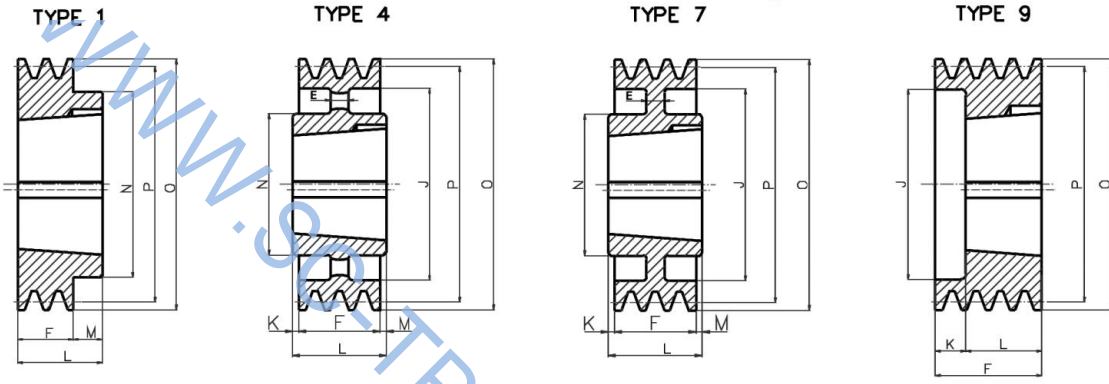

Item	Grooves	P	O	Type	Bush	Max Bore	E	F	J	K	L	M	N
SPZ 50-01	1	50	54	9	1008	25	-	37	28	15	22	-	-
SPZ 56-01	1	56	60	9	1008	25	-	37	23	15	22	-	-
SPZ 60-01	1	60	64	9	1008	25	-	22	-	-	22	-	-
SPZ 63-01	1	63	67	1	1108	28	-	16	-	-	22	6	62
SPZ 67-01	1	67	71	1	1108	28	-	16	-	-	22	6	62
SPZ 71-01	1	71	75	1	1108	28	-	16	-	-	22	6	62
SPZ 75-01	1	75	79	1	1108	28	-	16	-	-	22	6	62
SPZ 80-01	1	80	84	1	1210	32	-	16	-	-	25	9	75
SPZ 85-01	1	85	89	1	1210	32	-	16	-	-	25	9	75
SPZ 90-01	1	90	94	1	1210	32	-	16	-	-	25	-	75
SPZ 95-01	1	95	99	1	1210	32	-	16	-	-	25	9	75
SPZ 100-01	1	100	104	1	1210	32	-	16	-	-	25	9	75
SPZ 106-01	1	106	110	1	1610	42	-	16	-	-	25	9	80
SPZ 112-01	1	112	116	1	1610	42	-	16	-	-	25	9	80
SPZ 118-01	1	118	122	1	1610	42	-	16	-	-	25	9	80
SPZ 125-01	1	125	129	1	1610	42	-	16	-	-	25	9	80
SPZ 132-01	1	132	136	1	1610	42	-	16	-	-	25	9	80
SPZ 140-01	1	140	144	1	1610	42	-	16	-	-	25	9	80
SPZ 150-01	1	150	154	1	1610	42	-	16	-	-	25	9	80
SPZ 160-01	1	160	164	1	1610	42	-	16	-	-	25	9	80
SPZ 170-01	1	170	174	1	1610	42	-	16	-	-	25	9	80
SPZ 180-01	1	180	184	1	1610	42	-	16	-	-	25	9	80
SPZ 190-01	1	190	194	7	1610	42	-	16	161	-	25	9	80
SPZ 200-01	1	200	204	7	2012	50	-	16	172	-	32	16	100
SPZ 224-01	1	224	228	7	2012	50	-	16	196	-	32	16	100
SPZ 250-01	1	250	254	4	2012	50	-	16	222	8	32	8	100
SPZ 280-01	1	280	284	4	2012	50	-	16	252	8	32	8	100
SPZ 315-01	1	315	319	4	2012	50	-	16	287	8	32	8	100
SPZ 355-01	1	355	359	4	2012	50	-	16	326	8	32	8	112
SPZ 400-01	1	400	404	4	2012	50	-	16	371	8	32	8	112
SPZ 450-01	1	450	454	4	2517	60	-	16	421	14.5	45	14.5	120

V-Belt Pulleys

# SPZ/2 | V-Belt Pulleys For Taper Bushes



Taper Bore

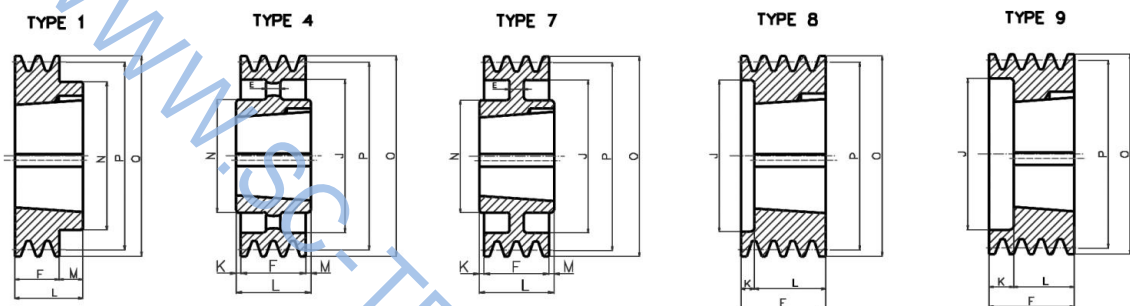

Item	Grooves	P	O	Type	Bush	Max Core	E	F	J	K	L	M	N
SPZ 50-02	2	50	54	9	1008	25	-	49	28	27	22	-	-
SPZ 56-02	2	56	60	9	1108	28	-	49	35	27	22	-	-
SPZ 60-02	2	60	64	9	1108	28	-	49	36	27	22	-	-
SPZ 63-02	2	63	67	8	1108	28	-	28	40	6	22	-	-
SPZ 67-02	2	67	71	8	1108	28	-	28	42	6	22	-	-
SPZ 71-02	2	71	75	8	1108	28	-	28	42	6	22	-	-
SPZ 75-02	2	75	79	8	1210	32	-	28	51	3	25	-	-
SPZ 80-02	2	80	84	8	1210	32	-	28	51	3	25	-	-
SPZ 85-02	2	85	89	8	1610	42	-	28	60	3	25	-	-
SPZ 90-02	2	90	94	8	1610	42	-	28	61	3	25	-	-
SPZ 95-02	2	95	99	8	1610	42	-	28	66	3	25	-	-
SPZ 100-02	2	100	104	8	1610	42	-	28	71	3	25	-	-
SPZ 106-02	2	106	110	8	1610	42	-	28	76	3	25	-	-
SPZ 112-02	2	112	116	8	1610	42	-	28	84	3	25	-	-
SPZ 118-02	2	118	122	8	1610	42	-	28	90	3	25	-	-
SPZ 125-02	2	125	129	8	1610	42	-	28	97	3	25	-	-
SPZ 132-02	2	132	136	8	1610	42	-	28	104	3	25	-	-
SPZ 140-02	2	140	146	8	1610	42	-	28	112	3	25	-	-
SPZ 150-02	2	150	154	1	2012	50	-	28	-	-	32	4	100
SPZ 160-02	2	160	164	1	2012	50	-	28	-	-	32	4	100
SPZ 170-02	2	170	174	1	2012	50	-	28	-	-	32	4	100
SPZ 180-02	2	180	184	7	2012	50	10	28	152	-	32	4	100
SPZ 190-02	2	190	194	7	2012	50	10	28	161	-	32	4	100
SPZ 200-02	2	200	204	7	2012	50	10	28	171	-	32	4	100
SPZ 224-02	2	224	228	7	2012	50	10	28	196	-	32	4	100
SPZ 250-02	2	250	254	4	2012	50	-	28	222	2	32	2	100
SPZ 280-02	2	280	284	4	2012	50	-	28	252	2	32	2	100
SPZ 315-02	2	315	319	4	2012	50	-	28	286	2	32	2	100
SPZ 355-02	2	355	359	4	2012	50	-	28	326	2	32	2	112
SPZ 400-02	2	400	404	4	2517	60	-	28	371	8.5	45	8.5	120
SPZ 450-02	2	450	454	4	2517	60	-	28	421	8.5	45	8.5	120

V-Belt Pulleys

# SPZ/3 | V-Belt Pulleys For Taper Bushes



Taper Bore

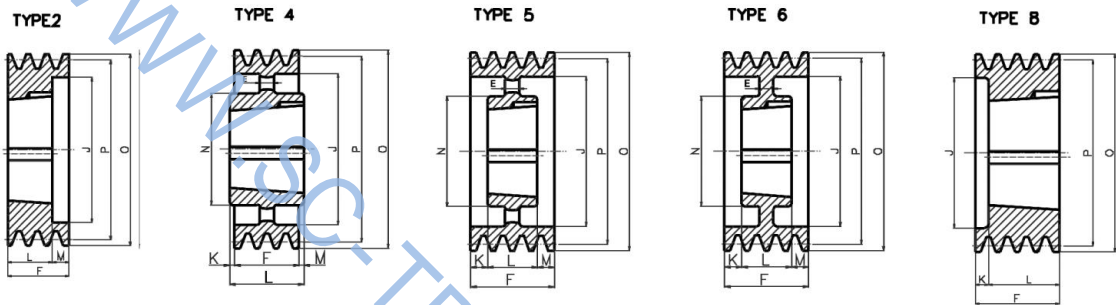

Item	Grooves	P	O	Type	Eush	Max Bore	E	F	J	K	L	M	N
SPZ 63-03	3	63	67	8	1108	28	-	40	40	18	22	-	-
SPZ 67-03	3	67	71	8	1108	28	-	40	42	18	22	-	-
SPZ 71-03	3	71	75	8	1108	28	-	40	42	18	22	-	-
SPZ 75-03	3	75	79	8	1210	32	-	40	48	15	25	-	-
SPZ 80-03	3	80	84	8	1210	32	-	40	51	15	25	-	-
SPZ 85-03	3	85	89	8	1610	42	-	40	60	15	25	-	-
SPZ 90-03	3	90	94	8	1610	42	-	40	61	15	25	-	-
SPZ 95-03	3	95	99	8	1610	42	-	40	66	15	25	-	-
SPZ 100-03	3	100	104	8	1610	42	-	40	71	15	25	-	-
SPZ 106-03	3	106	110	8	1610	42	-	40	78	15	25	-	-
SPZ 112-03	3	112	116	8	2012	50	-	40	81	8	32	-	-
SPZ 118-03	3	118	122	8	2012	50	-	40	92	8	32	-	-
SPZ 125-03	3	125	129	2	2012	50	-	40	97	-	32	8	-
SPZ 132-03	3	132	136	2	2012	50	-	40	104	-	32	8	-
SPZ 140-03	3	140	144	2	2012	50	-	40	112	-	32	8	-
SPZ 150-03	3	150	154	2	2012	50	-	40	122	-	32	8	-
SPZ 160-03	3	160	164	2	2012	50	-	40	132	-	32	8	-
SPZ 170-03	3	170	174	2	2012	50	-	40	141	-	32	4	-
SPZ 180-03	3	180	184	2	2012	50	-	40	152	-	32	8	-
SPZ 190-03	3	190	194	6	2012	50	20	40	161	4	32	4	100
SPZ 200-03	3	200	204	6	2012	50	20	40	172	4	32	4	100
SPZ 224-03	3	224	228	6	2012	50	20	40	196	4	32	4	100
SPZ 250-03	3	250	254	5	2012	50	-	40	222	4	32	4	100
SPZ 280-03	3	280	284	4	2517	60	-	40	252	2,5	45	2,5	120
SPZ 315-03	3	315	319	4	2517	60	-	40	287	2,5	45	2,5	120
SPZ 355-03	3	355	359	4	2517	60	-	40	326	2,5	45	2,5	120
SPZ 400-03	3	400	404	4	2517	60	-	40	371	2,5	45	2,5	120
SPZ 450-03	3	450	454	4	2517	60	-	40	421	2,5	45	2,5	120
SPZ 500-03	3	500	504	4	2517	60	-	40	471	2,5	45	2,5	120
SPZ 630-03	3	630	634	4	3020	75	-	40	601	5,5	51	2,5	120
SPZ 800-03	3	800	804	4	3020	75	-	40	771	5,5	51	2,5	150

V-Belt Pulleys

# SPZ/4 | V-Belt Pulleys For Taper Bushes



Taper Bore

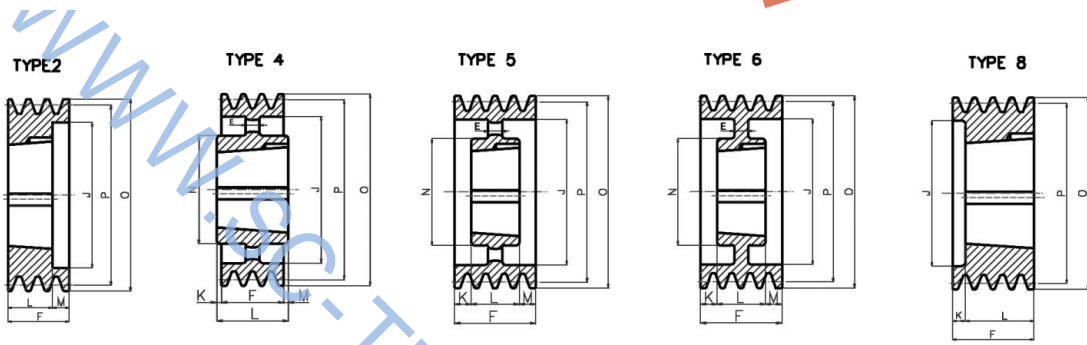

Item	Grooves	P	O	Type	Bush	Max Bore	E	F	J	K	L	M	N
SPZ 80-04	4	80	84	8	1210	32	-	52	51	27	25	-	-
SPZ 85-04	4	85	89	8	1610	42	-	52	60	27	25	-	-
SPZ 90-04	4	90	94	8	1610	42	-	52	61	27	25	-	-
SPZ 95-04	4	95	99	8	1610	42	-	52	66	27	25	-	-
SPZ 100-04	4	100	104	8	1610	42	-	52	72	27	25	-	-
SPZ 106-04	4	106	110	8	1610	42	-	52	80	27	25	-	-
SPZ 112-04	4	112	116	8	2012	50	-	52	86	20	32	-	-
SPZ 118-04	4	118	122	8	2012	50	-	52	92	20	32	-	-
SPZ 125-04	4	125	129	2	2012	50	-	52	99	20	32	20	-
SPZ 132-04	4	132	136	2	2012	50	-	52	104	20	32	20	-
SPZ 140-04	4	140	144	2	2012	50	-	52	112	7	32	20	-
SPZ 150-04	4	150	154	2	2517	60	-	52	122	7	45	7	-
SPZ 160-04	4	160	164	2	2517	60	-	52	132	-	45	7	-
SPZ 170-04	4	170	174	2	2517	60	-	52	141	-	45	7	-
SPZ 180-04	4	180	184	2	2517	60	-	52	152	-	45	7	-
SPZ 190-04	4	190	194	6	2517	60	10	52	161	3.5	45	3.5	120
SPZ 200-04	4	200	204	6	2517	60	10	52	172	3.5	45	3.5	120
SPZ 224-04	4	224	228	6	2517	60	10	52	196	3.5	45	3.5	120
SPZ 250-04	4	250	254	5	2517	60	-	52	222	3.5	45	3.5	120
SPZ 280-04	4	280	284	5	2517	60	-	52	252	3.5	45	3.5	120
SPZ 315-04	4	315	319	5	2517	60	-	52	287	3.5	45	3.5	120
SPZ 355-04	4	355	359	5	2517	60	-	52	326	3.5	45	3.5	120
SPZ 400-04	4	400	404	5	2517	60	-	52	371	3.5	45	3.5	120
SPZ 450-04	4	450	454	5	3020	75	-	52	421	0.5	51	0.5	150
SPZ 500-04	4	500	504	5	3020	75	-	52	471	0.5	51	0.5	150
SPZ 630-04	4	630	634	4	3030	75	-	52	601	12	76	12	150
SPZ 800-04	4	800	804	4	3030	75	-	52	771	12	76	12	150

# SPZ/5 | V-Belt Pulleys For Taper Bushes



Taper Bore

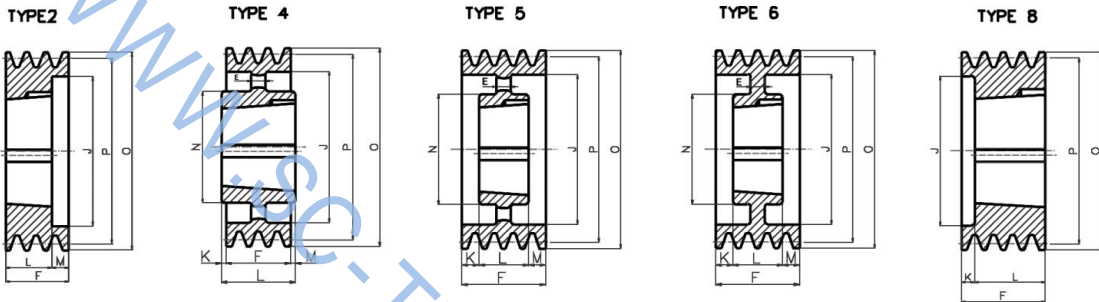

Item	Grooves	P	O	Type	Bush	Max Bore	E	F	J	K	L	M	N
SPZ 85-05	5	85	89	8	1610	42	-	64	60	39	25	-	-
SPZ 90-05	5	90	94	8	1610	42	-	64	61	39	25	-	-
SPZ 95-05	5	95	99	8	1610	42	-	64	66	39	25	-	-
SPZ 100-05	5	100	104	8	2012	50	-	64	72	32	32	-	-
SPZ 106-05	5	106	110	8	2012	50	-	64	78	32	32	-	-
SPZ 112-05	5	112	116	8	2012	50	-	64	84	32	32	-	-
SPZ 118-05	5	118	122	8	2012	50	-	64	90	32	32	-	-
SPZ 125-05	5	125	129	8	2012	50	-	64	97	32	32	-	-
SPZ 132-05	5	132	136	8	2517	60	-	64	104	19	45	-	-
SPZ 140-05	5	140	144	2	2517	60	-	64	112	-	45	19	-
SPZ 150-05	5	150	154	2	2517	60	-	64	122	-	45	19	-
SPZ 160-05	5	160	164	2	2517	60	-	64	132	-	45	19	-
SPZ 170-05	5	170	174	2	2517	60	-	64	141	-	45	19	-
SPZ 180-05	5	180	184	2	2517	60	-	64	152	-	45	19	-
SPZ 190-05	5	190	194	6	2517	60	10	64	161	9.5	45	9.5	-
SPZ 200-05	5	200	204	6	2517	60	10	64	172	9.5	45	9.5	-
SPZ 224-05	5	224	228	6	2517	60	10	64	196	9.5	45	9.5	120
SPZ 250-05	5	250	254	5	2517	60	-	64	222	9.5	45	9.5	120
SPZ 280-05	5	280	284	5	2517	60	-	64	252	9.5	45	9.5	120
SPZ 315-05	5	315	319	5	2517	60	-	64	287	9.5	45	9.5	120
SPZ 355-05	5	355	359	5	2517	60	-	64	326	9.5	45	9.5	120
SPZ 400-05	5	400	404	5	3020	75	-	64	371	6.5	51	6.5	150
SPZ 450-05	5	450	454	5	3020	75	-	64	421	6.5	51	6.5	150
SPZ 500-05	5	500	504	4	3030	75	-	64	471	6	76	6	150
SPZ 630-05	5	630	634	4	3030	75	-	64	601	6	76	6	150
SPZ 800-05	5	800	804	4	3535	90	-	64	771	12.5	89	12.5	170

V-Belt Pulleys

# SPZ/6 | V-Belt Pulleys For Taper Bushes



Taper Bore

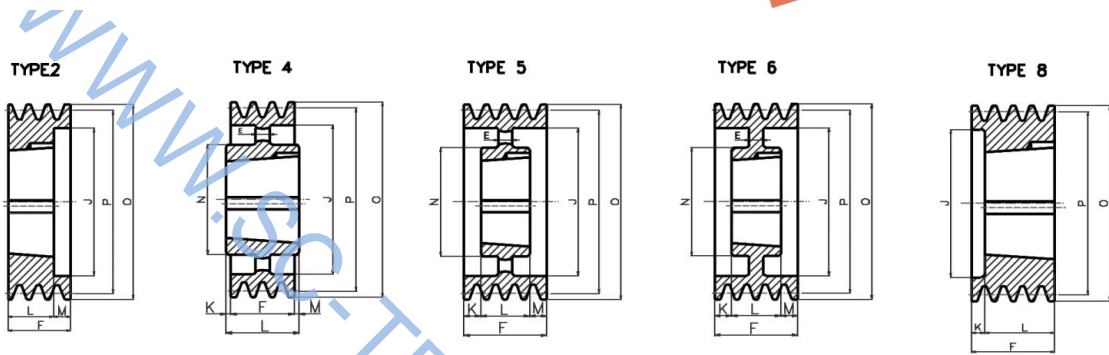

Item	Grooves	P	O	Type	Bush	Max Bore	E	F	J	K	L	M	N
SPZ 90-06	6	90	94	8	1610	42	-	76	61	51	25	-	-
SPZ 95-06	6	95	99	8	1610	42	-	76	66	51	25	-	-
SPZ 100-06	6	100	104	8	2012	50	-	76	72	44	32	-	-
SPZ 106-06	6	106	110	8	2012	50	-	76	78	44	32	-	-
SPZ 112-06	6	112	116	8	2012	50	-	76	84	44	32	-	-
SPZ 118-06	6	118	122	8	2517	60	-	76	90	31	45	-	-
SPZ 125-06	6	125	129	8	2517	60	-	76	97	31	45	-	-
SPZ 132-06	6	132	136	8	2517	60	-	76	104	31	45	-	-
SPZ 140-06	6	140	144	2	2517	60	-	76	112	-	45	31	-
SPZ 150-06	6	150	154	2	2517	60	-	76	122	-	45	31	-
SPZ 160-06	6	160	164	2	2517	60	-	76	132	-	45	31	-
SPZ 170-06	6	170	174	2	2517	60	-	76	141	-	45	31	-
SPZ 180-06	6	180	184	2	2517	60	-	76	152	-	45	31	-
SPZ 190-06	6	190	194	6	2517	60	10	76	161	15.5	45	15.5	120
SPZ 200-06	6	200	204	6	2517	60	10	76	172	15.5	45	15.5	120
SPZ 224-06	6	224	228	6	2517	60	10	76	196	15.5	45	15.5	120
SPZ 250-06	6	250	254	5	2517	60	-	76	222	15.5	45	15.5	120
SPZ 280-06	6	280	284	5	2517	60	-	76	252	15.5	45	15.5	120
SPZ 315-06	6	315	319	5	2517	60	-	76	287	15.5	45	15.5	120
SPZ 355-06	6	355	359	5	2517	60	-	76	326	15.5	45	15.5	125
SPZ 400-06	6	400	404	5	3030	75	-	76	371	-	76	-	150
SPZ 450-06	6	450	454	5	3030	75	-	76	421	-	76	-	150
SPZ 500-06	6	500	504	5	3030	75	-	76	471	-	76	-	150
SPZ 630-06	6	630	634	4	3535	90	-	76	601	6.5	89	6.5	170
SPZ 800-06	6	800	804	4	3535	90	-	76	771	6.5	89	6.5	170



# SPZ/8 | V-Belt Pulleys For Taper Bushes



Taper Bore

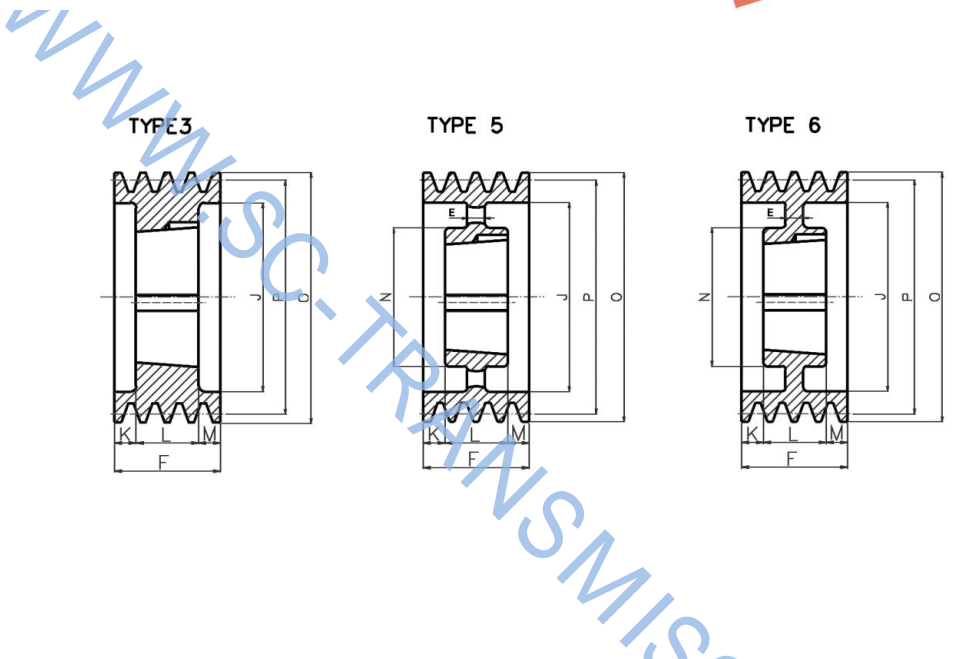

Item	Grooves	P	O	Type	Bush	Max Bore	E	F	J	K	L	M	N
SPZ 140-08	8	140	144	3	2517	60	-	100	112	27.5	45	27.5	-
SPZ 150-08	8	150	154	3	2517	60	-	100	122	27.5	45	27.5	-
SPZ 160-08	8	160	164	3	2517	60	-	100	132	27.5	45	27.5	-
SPZ 180-08	8	180	184	3	2517	60	-	100	152	27.5	45	27.5	-
SPZ 200-08	8	200	204	3	3020	75	-	100	171	24.5	51	24.5	-
SPZ 224-08	8	224	228	3	3020	75	-	100	195	24.5	51	24.5	-
SPZ 250-08	8	250	254	6	3020	75	-	100	221	24.5	51	24.5	150
SPZ 280-08	8	280	284	5	3020	75	-	100	252	24.5	51	24.5	150
SPZ 355-08	8	355	359	5	3030	75	-	100	326	12	76	12	150
SPZ 400-08	8	400	404	5	3030	75	-	100	371	12	76	12	150
SPZ 450-08	8	450	454	5	3035	90	-	100	421	5.5	89	5.5	170

V-Belt Pulleys

# SPA/1 | V-Belt Pulleys For Taper Bushes



Taper Bore

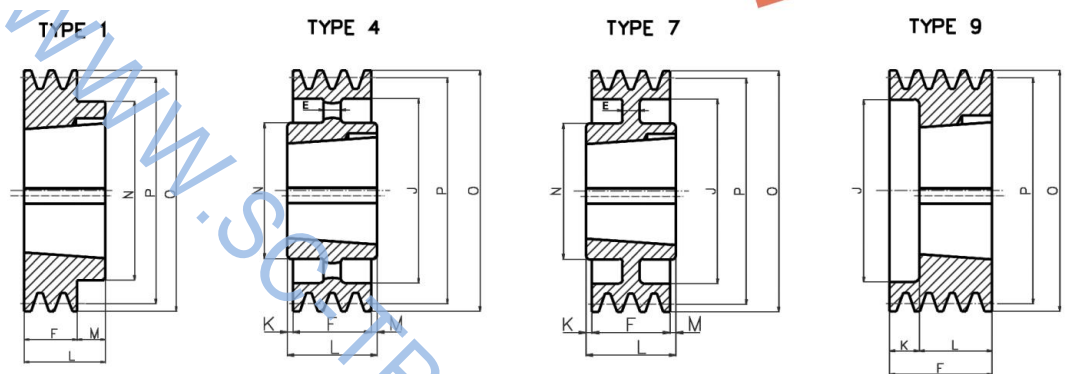

Item	Grooves	P	O	Type	Bush	Max Bore	E	F	J	K	L	M	N
SPA 63-01	1	63	68.5	9	1008	25	-	40	38	18	22	-	-
SPA 67-01	1	67	72.5	1	1108	23	-	20	38	-	22	2	62
SPA 71-01	1	71	76.5	1	1108	28	-	20	-	-	22	2	62
SPA 75-01	1	75	80.5	1	1108	28	-	20	-	-	22	2	62
SPA 80-01	1	80	85.5	1	1210	32	-	20	-	-	25	5	75
SPA 85-01	1	85	90.5	1	1210	32	-	20	-	-	25	5	75
SPA 90-01	1	90	95.5	1	1210	32	-	20	-	-	25	5	75
SPA 95-01	1	95	100.5	1	1210	32	-	20	-	-	25	5	75
SPA 100-01	1	100	105.5	1	1610	42	-	20	-	-	25	5	80
SPA 106-01	1	106	111.5	1	1610	42	-	20	-	-	25	5	80
SPA 112-01	1	112	117.5	1	1610	42	-	20	-	-	25	5	80
SPA 118-01	1	118	123.5	1	1610	42	-	20	-	-	25	5	80
SPA 125-01	1	125	130.5	1	1610	42	-	20	-	-	25	5	80
SPA 132-01	1	132	137.5	1	1610	42	-	20	-	-	25	5	80
SPA 140-01	1	140	145.5	1	1610	42	-	20	-	-	25	5	80
SPA 150-01	1	150	155.5	1	1610	42	-	20	-	-	25	5	80
SPA 160-01	1	160	165.5	1	1610	42	-	20	-	-	25	5	80
SPA 170-01	1	170	175.5	1	1610	42	-	20	-	-	25	5	80
SPA 180-01	1	180	185.5	1	1610	42	-	20	-	-	25	5	80
SPA 190-01	1	190	195.5	1	1610	42	-	20	-	-	25	5	80
SPA 200-01	1	200	205.5	7	2012	50	10	20	165	6	32	6	100
SPA 212-01	1	212	217.5	7	2012	50	10	20	177	6	32	6	100
SPA 224-01	1	224	229.5	7	2012	50	10	20	189	6	32	6	100
SPA 250-01	1	250	255.5	7	2012	50	10	20	215	6	32	6	100
SPA 280-01	1	280	285.5	7	2012	50	10	20	245	6	32	6	100
SPA 315-01	1	315	320.5	7	2012	50	-	20	280	6	32	6	100
SPA 355-01	1	355	360.5	4	2012	50	-	20	320	6	32	6	100
SPA 400-01	1	400	405.5	4	2012	50	-	20	365	6	32	6	100
SPA 450-01	1	450	455.5	4	2012	50	-	20	415	6	32	6	100
SPA 500-01	1	500	505.5	4	2517	60	-	20	465	-	45	25	120
SPA 630-01	1	630	635.5	4	2517	60	-	20	595	-	45	25	120

# SPA/2 | V-Belt Pulleys For Taper Bushes



Taper Bore

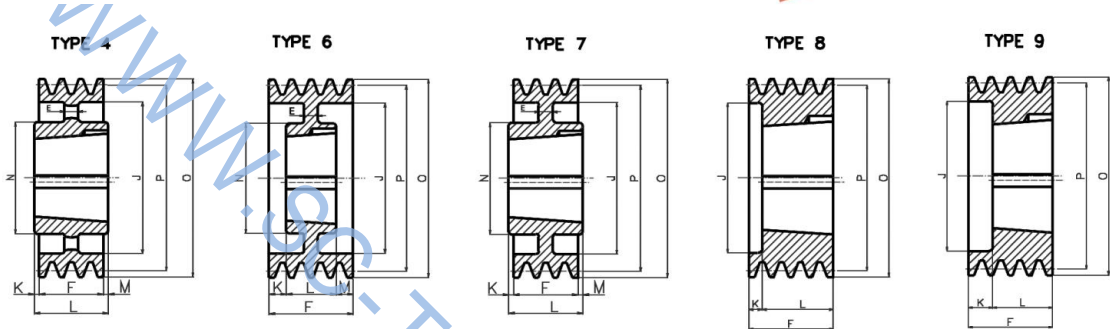

Item	Grooves	P	O	Type	Bush	Max Bore	E	F	J	K	L	M	N
SPA 63-02	2	63	68.5	9	1008	28	-	55	36	33	22	-	-
SPA 67-02	2	67	72.5	8	1108	28	-	35	37	13	22	-	-
SPA 71-02	2	71	76.5	8	1108	28	-	35	40	13	22	-	-
SPA 75-02	2	75	80.5	8	1108	28	-	35	44	10	22	-	-
SPA 80-02	2	80	85.5	8	1210	32	-	35	47	10	25	-	-
SPA 85-02	2	85	90.5	8	1210	32	-	35	50	10	25	-	-
SPA 90-02	2	90	95.5	8	1610	42	-	35	60	10	25	-	-
SPA 95-02	2	95	100.5	8	1610	42	-	35	64	10	25	-	-
SPA 100-02	2	100	105.5	8	1610	42	-	35	70	10	25	-	-
SPA 106-02	2	106	111.5	8	1610	42	-	35	76	10	25	-	-
SPA 112-02	2	112	117.5	8	1610	42	-	35	80	10	25	-	-
SPA 118-02	2	118	123.5	8	1610	42	-	35	86	10	25	-	-
SPA 125-02	2	125	130.5	8	1610	42	-	35	90	10	25	-	-
SPA 132-02	2	132	137.5	8	2012	50	-	35	98	3	32	-	-
SPA 140-02	2	140	145.5	8	2012	50	-	35	106	3	32	-	-
SPA 150-02	2	150	155.5	8	2012	50	-	35	116	3	32	-	-
SPA 160-02	2	160	165.5	8	2012	50	15	35	125	3	32	-	-
SPA 170-02	2	170	175.5	8	2012	50	15	35	135	3	32	-	-
SPA 180-02	2	180	185.5	6	2012	50	15	35	148	1.5	32	1.5	100
SPA 190-02	2	190	195.5	6	2012	50	15	35	158	1.5	32	1.5	100
SPA 200-02	2	200	205.5	7	2517	60	15	35	165	5	45	5	120
SPA 212-02	2	212	217.5	7	2517	60	15	35	177	5	45	5	120
SPA 224-02	2	224	229.5	7	2517	60	15	35	189	-	45	10	120
SPA 250-02	2	250	255.5	7	2517	60	20	35	215	5	45	5	120
SPA 280-02	2	280	285.5	7	2517	60	20	35	245	-	45	10	120
SPA 315-02	2	315	320.5	4	2517	60	-	35	280	-	45	10	120
SPA 355-02	2	355	360.5	4	2517	60	-	35	320	-	45	10	120
SPA 400-02	2	400	405.5	4	2517	60	-	35	365	-	45	10	120
SPA 450-02	2	450	455.5	4	2517	60	-	35	465	-	45	10	120
SPA 500-02	2	500	505.5	4	2517	60	-	35	525	-	45	16	150
SPA 630-02	2	630	635.5	4	3020	75	-	35	595	-	51	16	150

V-Belt Pulleys

# SPA/3 | V-Belt Pulleys For Taper Bushes



Taper Bore

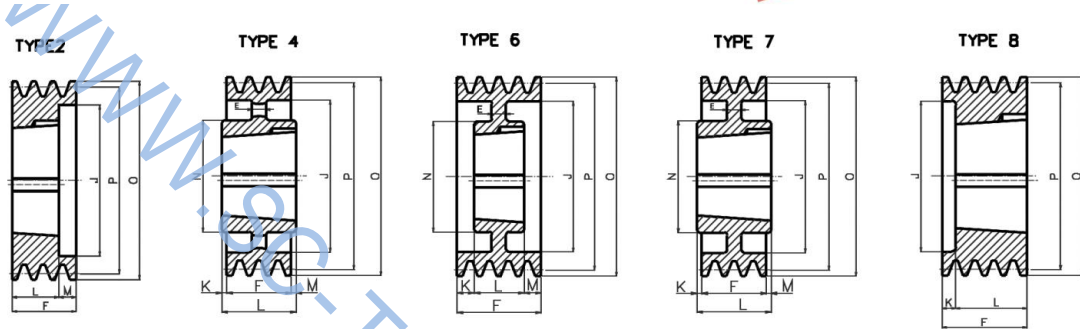

Item	Grooves	P	O	Type	Bush	Max Bore	E	F	J	K	L	M	N
SPA 71-03	3	71	76.5	8	1108	28	-	50	40	28	22	-	-
SPA 75-03	3	75	80.5	8	1210	32	-	50	44	25	25	-	-
SPA 80-03	3	80	85.5	8	1210	32	-	50	47	25	25	-	-
SPA 85-03	3	85	90.5	8	1210	32	-	50	50	25	25	-	-
SPA 90-03	3	90	95.5	8	1610	42	-	50	60	25	25	-	-
SPA 95-03	3	95	100.5	8	1610	42	-	50	64	25	25	-	-
SPA 100-03	3	100	105.5	2	1610	42	-	50	70	-	25	25	-
SPA 106-03	3	106	111.5	2	1610	42	-	50	76	-	25	25	-
SPA 112-03	3	112	117.5	8	2012	50	-	50	83	18	32	-	-
SPA 118-03	3	118	123.5	2	2012	50	-	50	86	-	32	18	-
SPA 125-03	3	125	130.5	2	2012	50	-	50	92	-	32	18	-
SPA 132-03	3	132	137.5	2	2012	50	-	50	98	-	32	18	-
SPA 140-03	3	140	145.5	8	2517	60	-	50	106	5	45	-	-
SPA 150-03	3	150	155.5	8	2517	60	-	50	116	5	45	-	-
SPA 160-03	3	160	165.5	8	2517	60	-	50	126	5	45	-	-
SPA 170-03	3	170	175.5	8	2517	60	-	50	138	5	45	-	-
SPA 180-03	3	180	185.5	8	2517	60	-	50	146	5	45	-	-
SPA 190-03	3	190	195.5	8	2517	60	-	50	158	5	45	-	-
SPA 200-03	3	200	205.5	6	2517	60	20	50	165	2.5	45	2.5	120
SPA 212-03	3	212	217.5	6	2517	60	20	50	177	2.5	45	2.5	120
SPA 224-03	3	224	229.5	6	2517	60	20	50	189	2.5	45	2.5	120
SPA 250-03	3	250	255.5	6	2517	60	20	50	215	2.5	45	2.5	120
SPA 280-03	3	280	285.5	6	2517	60	20	50	245	2.5	45	2.5	120
SPA 315-03	3	315	320.5	7	3020	75	25	50	280	0.5	51	0.5	150
SPA 355-03	3	355	360.5	4	3020	75	-	50	320	0.5	51	0.5	150
SPA 400-03	3	400	405.5	4	3020	75	-	50	365	0.5	51	0.5	150
SPA 450-03	3	450	455.5	4	3020	75	-	50	415	0.5	51	0.5	150
SPA 500-03	3	500	505.5	4	3020	75	-	50	465	0.5	51	0.5	150
SPA 560-03	3	560	565.5	4	3020	75	-	50	525	0.5	51	0.5	150
SPA 630-03	3	630	635.5	4	3020	75	-	50	595	0.5	51	0.5	150
SPA 800-03	3	800	805.5	4	3535	90	-	50	765	19.5	89	19.5	170
SPA 1000-03	3	1000	1005.5	4	3535	90	-	50	965	19.5	89	19.5	178

# SPA/4 | V-Belt Pulleys For Taper Bushes



Taper Bore

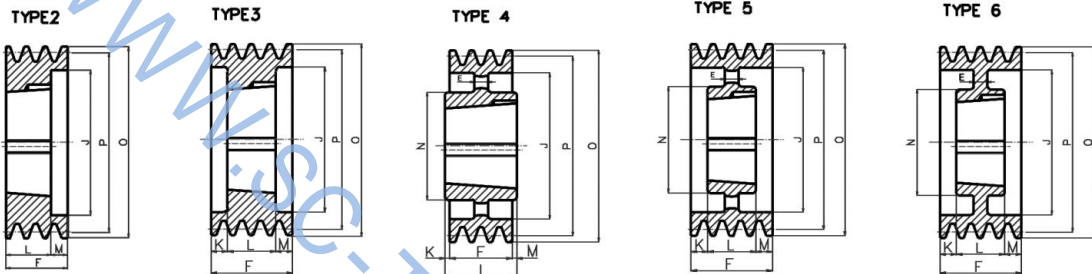

Item	Grooves	P	O	Type	Bush	Max Bore	E	F	J	K	L	M	N
SPA 90-04	4	90	95.5	3	1615	42	-	65	64	13.5	38	13.5	-
SPA 95-04	4	95	100.5	3	1615	42	-	65	64	13.5	38	13.5	-
SPA 100-04	4	100	105.5	2	1615	42	-	65	70	-	38	27	-
SPA 106-04	4	106	111.5	8	2012	50	-	65	76	33	32	-	-
SPA 112-04	4	112	117.5	8	2012	50	-	65	80	33	32	-	-
SPA 118-04	4	118	123.5	2	2012	50	-	65	86	-	32	33	-
SPA 125-04	4	125	130.5	2	2012	50	-	65	92	-	32	33	-
SPA 132-04	4	132	137.5	2	2517	60	-	65	98	-	45	20	-
SPA 140-04	4	140	145.5	2	2517	60	-	65	106	-	45	20	-
SPA 150-04	4	150	155.5	2	2517	60	-	65	116	-	45	20	-
SPA 160-04	4	160	165.5	2	2517	60	-	65	126	-	45	20	-
SPA 170-04	4	170	175.5	2	2517	60	-	65	138	-	45	20	-
SPA 180-04	4	180	185.5	2	2517	60	-	65	146	-	45	20	-
SPA 190-04	4	190	195.5	2	2517	60	-	65	158	-	45	20	-
SPA 200-04	4	200	205.5	2	3020	75	-	65	165	-	51	14	-
SPA 212-04	4	212	217.5	2	3020	75	-	65	177	-	51	14	-
SPA 224-04	4	224	229.5	2	3020	75	-	65	189	-	51	14	-
SPA 250-04	4	250	255.5	6	3020	75	10	65	215	7	51	7	150
SPA 280-04	4	280	285.5	6	3020	75	10	65	245	7	51	7	150
SPA 315-04	4	315	320.5	6	3020	75	10	65	280	7	51	7	150
SPA 355-04	4	355	360.5	5	3020	75	-	65	320	7	51	7	150
SPA 400-04	4	400	405.5	5	3020	75	-	65	365	7	51	7	150
SPA 450-04	4	450	455.5	5	3020	75	-	65	415	7	51	7	150
SPA 500-04	4	500	505.5	5	3020	75	-	65	465	7	51	7	150
SPA 560-04	4	560	565.5	4	3535	90	-	65	525	12	89	12	170
SPA 630-04	4	630	635.5	4	3535	90	-	65	595	12	89	12	170
SPA 800-04	4	800	805.5	4	3535	90	-	65	765	12	89	12	170
SPA 1000-04	4	1000	1005.5	4	4040	90	-	65	965	18.5	102	18.5	216

V-Belt Pulleys

# SPA/5 | V-Belt Pulleys For Taper Bushes



Taper Bore

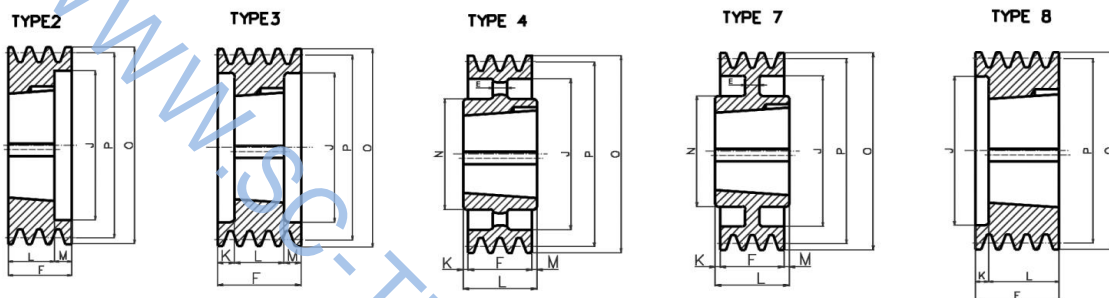

Item	Grooves	P	O	Type	Bush	Max Bore	E	F	J	K	L	M	N
SPA 100-05	5	100	105.5	2	1615	42	-	80	70	-	38	42	-
SPA 106-05	5	106	111.5	8	2012	50	-	80	76	48	32	-	-
SPA 112-05	5	112	117.5	8	2012	50	-	80	80	48	32	-	-
SPA 118-05	5	118	123.5	2	2012	50	-	80	86	-	32	48	-
SPA 125-05	5	125	130.5	3	2012	50	-	80	92	24	32	24	-
SPA 132-05	5	132	137.5	3	2517	60	-	80	98	17.5	45	17.5	-
SPA 140-05	5	140	145.5	3	2517	60	-	80	106	17.5	45	17.5	-
SPA 150-05	5	150	155.5	3	2517	60	-	80	116	17.5	45	17.5	-
SPA 160-05	5	160	165.5	3	2517	60	-	80	126	17.5	45	17.5	-
SPA 170-05	5	170	175.5	3	2517	75	-	80	146	17.5	45	17.5	-
SPA 180-05	5	180	185.5	3	3020	75	-	80	165	14.5	51	14.5	-
SPA 190-05	5	190	195.5	2	3020	75	-	80	189	-	51	29	-
SPA 200-05	5	200	205.5	3	3020	75	-	80	215	14.5	51	14.5	-
SPA 212-05	5	212	217.5	2	3020	75	-	80	245	-	51	29	-
SPA 224-05	5	224	229.5	2	3020	75	-	80	280	-	51	29	-
SPA 250-05	5	250	255.5	6	3020	75	10	80	215	14.5	51	14.5	150
SPA 280-05	5	280	285.5	7	3535	90	10	80	245	4.5	89	4.5	170
SPA 315-05	5	315	320.5	7	3535	90	12	80	280	4.5	89	4.5	170
SPA 355-05	5	355	360.5	4	3535	90	-	80	320	4.5	89	4.5	170
SPA 400-05	5	400	405.5	4	3535	90	-	80	365	4.5	89	4.5	170
SPA 450-05	5	450	455.5	4	3535	90	-	80	415	4.5	89	4.5	170
SPA 500-05	5	500	505.5	4	3535	90	-	80	465	4.5	89	4.5	170
SPA 560-05	5	560	565.5	4	3535	90	-	80	525	4.5	89	4.5	170
SPA 630-05	5	630	635.5	4	3535	90	-	80	595	4.5	89	4.5	170
SPA 800-05	5	800	805.5	4	4040	100	-	80	765	11	102	11	216
SPA 1000-05	5	1000	1005.5	4	4545	110	-	80	965	17	114	17	225

# SPA/6 | V-Belt Pulleys For Taper Bushes



Taper Bore

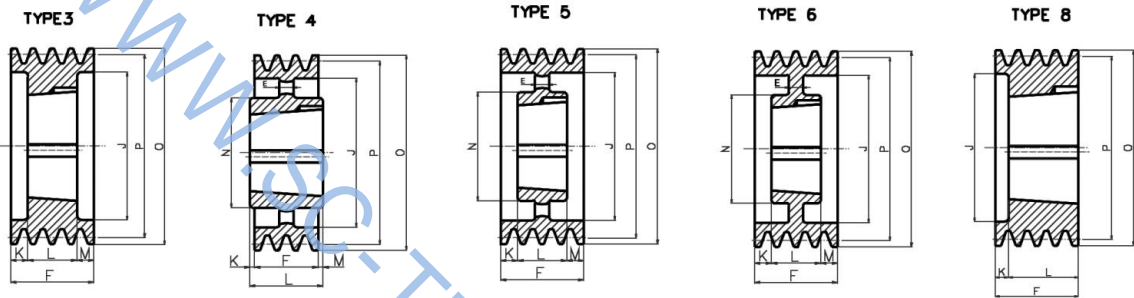

Item	Grooves	P	O	Type	E	Max Bore	E	F	J	K	L	M	N
SPA 100-06	6	100	105.5	3	1615	42	-	95	70	28.5	38	28.5	-
SPA 106-06	6	106	111.5	8	2012	50	-	95	76	63	32	-	-
SPA 112-06	6	112	117.5	8	2012	50	-	95	80	63	32	-	-
SPA 118-06	6	118	123.5	8	2012	50	-	95	86	63	32	-	-
SPA 125-06	6	125	130.5	3	2012	50	-	95	92	31.5	32	31.5	-
SPA 132-06	6	132	137.5	3	2517	60	-	95	98	25	45	25	-
SPA 140-06	6	140	145.5	3	2517	60	-	95	105	25	45	25	-
SPA 150-06	6	150	155.5	3	2517	60	-	95	115	25	45	25	-
SPA 160-06	6	160	165.5	3	2517	60	-	95	125	25	45	25	-
SPA 180-06	6	180	185.5	3	3020	75	-	95	146	22	51	22	-
SPA 200-06	6	200	205.5	3	3020	75	-	95	165	22	51	22	-
SPA 224-06	6	224	229.5	3	3020	75	-	95	189	22	51	22	-
SPA 250-06	6	250	255.5	6	3020	75	20	95	215	22	51	22	150
SPA 280-06	6	280	285.5	6	3535	90	25	95	245	3	89	3	170
SPA 315-06	6	315	320.5	6	3535	90	25	95	280	3	89	3	170
SPA 355-06	6	355	360.5	5	3535	90	-	95	320	3	89	3	170
SPA 400-06	6	400	405.5	5	3535	90	-	95	365	3	89	3	170
SPA 450-06	6	450	455.5	5	3535	90	-	95	415	3	89	3	170
SPA 500-06	6	500	505.5	5	3535	90	-	95	465	3	89	3	170
SPA 560-06	6	560	565.5	5	3535	90	-	95	525	3	89	3	170
SPA 630-06	6	630	635.5	4	4040	100	-	95	595	3.5	102	3.5	216
SPA 800-06	6	800	805.5	4	4040	100	-	95	765	3.5	102	3.5	216
SPA 1000-06	6	1000	1005.5	4	4545	110	-	95	965	9.5	114	9.5	225

V-Belt Pulleys

# SPB/1 | V-Belt Pulleys For Taper Bushes



Taper Bore

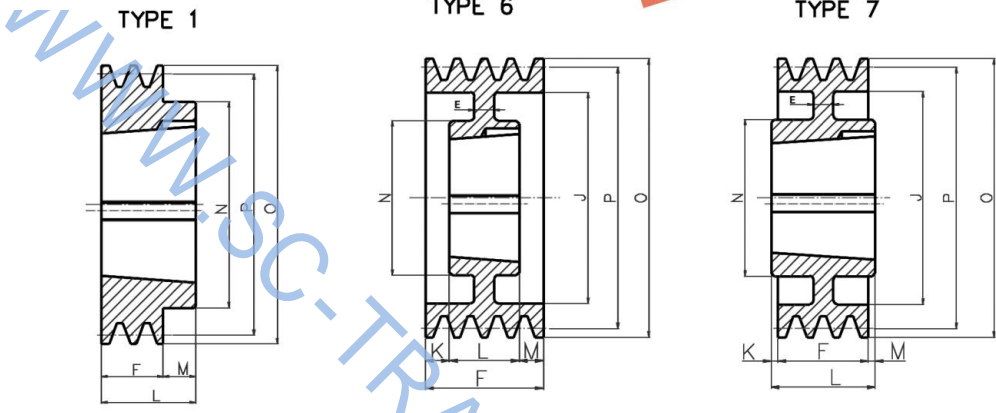

Item	Grooves	P	O	Type	Bush	Max Bore	E	F	J	K	L	M	N
SPB100-06	1	100	107	1	1610	42	-	25	-	-	25	-	-
SPB106-06	1	106	113	1	1610	42	-	25	-	-	25	-	-
SPB112-06	1	112	119	1	1610	42	-	25	-	-	25	-	-
SPB118-06	1	118	125	1	1610	42	-	25	-	-	25	-	-
SPB125-06	1	125	132	1	1610	42	-	25	-	-	25	-	-
SPB132-06	1	132	139	1	1610	42	-	25	-	-	25	-	-
SPB140-06	1	140	147	1	1610	42	-	25	-	-	25	-	-
SPB150-06	1	150	157	1	1610	42	-	25	-	-	25	-	-
SPB160-06	1	160	167	1	1610	42	-	25	-	-	25	-	-
SPB170-06	1	170	177	1	1610	42	-	25	-	-	25	-	-
SPB180-06	1	180	187	6	1610	42	10	25	137	-	25	-	80
SPB190-01	1	190	197	7	2012	50	10	25	147	3.5	32	3.5	100
SPB200-06	1	200	207	7	2012	50	10	25	157	3.5	32	3.5	100
SPB212-01	1	212	219	7	2012	50	10	25	169	3.5	32	3.5	100
SPB224-06	1	224	231	7	2012	50	10	25	181	3.5	32	3.5	100
SPB236-01	1	236	243	7	2012	50	10	25	193	3.5	32	3.5	100
SPB250-06	1	250	257	7	2012	50	10	25	207	3.5	32	3.5	100
SPB280-06	1	280	287	7	2012	50	10	25	237	3.5	32	3.5	100
SPB300-01	1	300	307	7	2012	50	10	25	258	3.5	32	3.5	100
SPB315-06	1	315	322	7	2012	50	10	25	272	3.5	32	3.5	100

V-Belt Pulleys



# SPB/2 | V-Belt Pulleys For Taper Bushes



Taper Bore

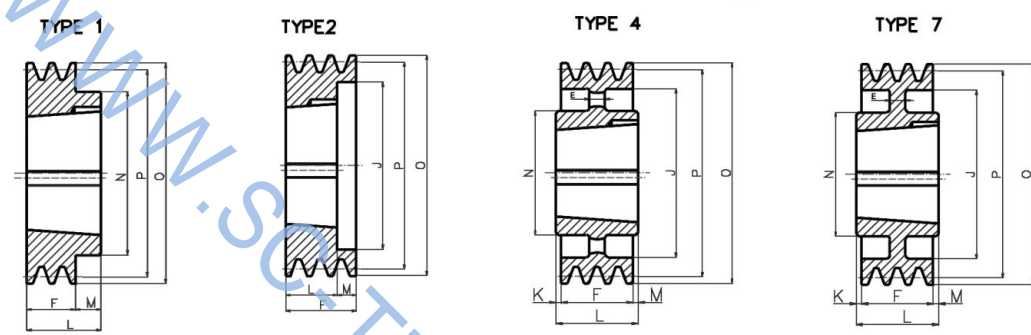

Item	Grooves	P	O	Type	Bush	Max Bore	E	F	J	K	L	M	N
SPB 100-02	2	100	107	2	1610	42	-	44	62	-	25	19	-
SPB 106-02	2	106	113	2	1610	42	-	44	67	-	25	19	-
SPB 112-02	2	112	119	2	1610	42	-	44	72	-	25	19	-
SPB 118-02	2	118	125	2	1610	42	-	44	78	-	25	19	-
SPB 125-02	2	125	132	2	2012	50	-	44	82	-	32	12	-
SPB 132-02	2	132	139	2	2012	50	-	44	89	-	32	12	-
SPB 140-02	2	140	147	2	2012	50	-	44	97	-	32	12	-
SPB 150-02	2	150	157	2	2012	50	-	44	107	-	32	12	-
SPB 160-02	2	160	167	2	2012	50	-	44	117	-	32	12	-
SPB 170-02	2	170	177	2	2012	50	-	44	127	-	32	12	-
SPB 180-02	2	180	187	1	2517	60	-	44	-	-	45	1	120
SPB 190-02	2	190	197	1	2517	60	-	44	-	-	45	1	120
SPB 200-02	2	200	207	1	2517	60	-	44	-	-	45	1	120
SPB 212-02	2	212	219	7	2517	60	10	44	169	-	45	1	120
SPB 224-02	2	224	231	7	2517	60	10	44	181	-	45	1	120
SPB 236-02	2	236	243	7	2517	60	10	44	193	-	45	1	120
SPB 250-02	2	250	257	7	2517	60	10	44	207	-	45	1	120
SPB 280-02	2	280	287	7	2517	60	12	44	237	-	45	1	120
SPB 300-02	2	300	307	7	2517	60	12	44	257	-	45	1	120
SPB 315-02	2	315	322	7	2517	60	12	44	272	-	45	1	120
SPB 335-02	2	335	342	7	2517	60	12	44	292	-	45	1	120
SPB 355-02	2	355	362	4	3020	75	-	44	312	3.5	51	3.5	120
SPB 400-02	2	400	407	4	3020	75	-	44	357	3.5	51	3.5	150
SPB 450-02	2	450	457	4	3020	75	-	44	407	3.5	51	3.5	150
SPB 500-02	2	500	507	4	3020	75	-	44	457	3.5	51	3.5	150
SPB 560-02	2	560	567	4	3030	75	-	44	517	4	76	28	150
SPB 630-02	2	630	637	4	3030	75	-	44	587	4	76	16	150

V-Belt Pulleys

# SPB/3 | V-Belt Pulleys For Taper Bushes



Taper Bore

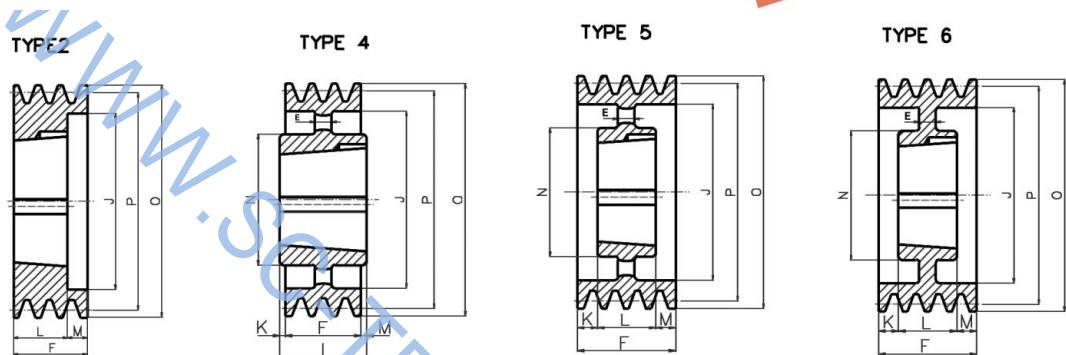

Item	Grooves	P	O	Type	Bush	Max Bore	E	F	J	K	L	M	N
SPB 100-03	3	100	107	2	1610	42	-	63	57	-	25	38	-
SPB 106-03	3	106	113	2	1610	42	-	63	67	-	25	38	-
SPB 112-03	3	112	119	2	1610	42	-	63	72	-	25	38	-
SPB 118-03	3	118	125	2	1610	42	-	63	78	-	25	38	-
SPB 125-03	3	125	132	2	2012	50	-	63	82	-	32	31	-
SPB 132-03	3	132	139	2	2012	50	-	63	89	-	32	31	-
SPB 140-03	3	140	147	2	2012	50	-	63	97	-	32	31	-
SPB 150-03	3	150	157	2	2517	60	-	63	107	-	45	18	-
SPB 160-03	3	160	167	2	2517	60	-	63	117	-	45	18	-
SPB 170-03	3	170	177	2	2517	60	-	63	127	-	45	18	-
SPB 180-03	3	180	187	2	2517	60	-	63	137	-	45	18	-
SPB 190-03	3	190	197	2	2517	60	-	63	147	-	45	18	-
SPB 200-03	3	200	207	2	2517	60	-	63	157	-	45	18	-
SPB 212-03	3	212	219	6	2517	60	15	63	169	-	45	18	120
SPB 224-03	3	224	231	6	2517	60	15	63	181	-	45	18	120
SPB 236-03	3	236	243	6	2517	60	15	63	193	-	45	18	120
SPB 250-03	3	250	257	6	3020	75	20	63	207	-	51	12	150
SPB 280-03	3	280	287	6	3020	75	20	63	237	6	51	6	150
SPB 300-03	3	300	307	6	3020	75	20	63	257	6	51	6	150
SPB 315-03	3	315	322	6	3020	75	20	63	272	6	51	6	150
SPB 335-03	3	335	342	6	3020	75	20	63	292	6	51	6	150
SPB 355-03	3	355	362	5	3020	75	15	63	312	6	51	6	150
SPB 400-03	3	400	407	4	3535	90	-	63	357	13	89	13	170
SPB 450-03	3	450	457	4	3535	90	-	63	407	-	89	26	170
SPB 500-03	3	500	507	4	3535	90	-	63	457	-	89	26	170
SPB 560-03	3	560	567	4	3535	90	-	63	517	-	89	26	170
SPB 630-03	3	630	637	4	3535	90	-	63	587	-	89	26	170
SPB 710-03	3	710	717	4	3535	90	-	63	664	4	89	22	170
SPB 800-03	3	800	807	4	3535	90	-	63	754	4	89	22	170
SPB 900-03	3	900	907	4	3535	90	-	63	854	4	89	22	170
SPB 1000-03	3	1000	1007	4	4040	100	-	63	954	6	102	33	200
SPB 1250-03	3	1250	1257	4	4040	100	-	63	1204	6	102	33	200

V-Belt Pulleys

# SPB/4 | V-Belt Pulleys For Taper Bushes



Taper Bore

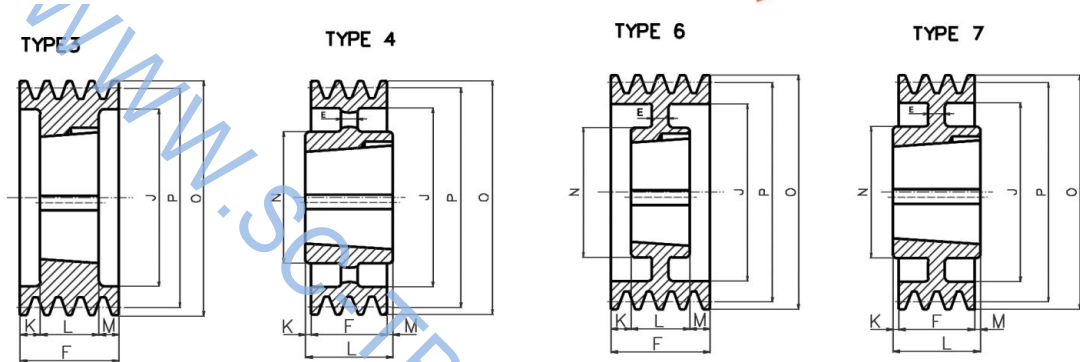

Item	Grooves	P	O	Type	Bush	Max Bore	E	F	J	K	L	M	N
SPB 125-04	4	125	132	3	2012	50	-	82	82	25	32	25	-
SPB 132-04	4	132	139	3	2012	50	-	82	89	25	32	25	-
SPB 140-04	4	140	147	3	2517	60	-	82	97	18.5	45	18.5	-
SPB 150-04	4	150	157	3	2517	60	-	82	107	18.5	45	18.5	-
SPB 160-04	4	160	167	3	2517	60	-	82	117	18.5	45	18.5	-
SPB 170-04	4	170	177	3	2517	60	-	82	127	18.5	45	18.5	-
SPB 180-04	4	180	187	3	2517	60	-	82	137	18.5	45	18.5	-
SPB 190-04	4	190	197	3	2517	60	-	82	147	18.5	45	18.5	-
SPB 200-04	4	200	207	3	3020	75	-	82	157	15.5	51	15.5	-
SPB 212-04	4	212	219	3	3020	75	-	82	169	15.5	51	15.5	-
SPB 224-04	4	224	231	3	3020	75	-	82	181	15.5	51	15.5	-
SPB 236-04	4	236	243	3	3020	75	-	82	193	15.5	51	15.5	150
SPB 250-04	4	250	257	6	3020	75	25	82	207	15.5	51	15.5	150
SPB 280-04	4	280	287	6	3020	75	25	82	237	15.5	51	15.5	150
SPB 300-04	4	300	307	6	3535	90	25	82	257	15.5	89	7	170
SPB 315-04	4	315	322	7	3535	90	25	82	272	3.5	89	3.5	170
SPB 335-04	4	335	342	7	3535	90	25	82	292	3.5	89	3.5	170
SPB 355-04	4	355	362	7	3535	90	25	82	312	3.5	89	3.5	170
SPB 400-04	4	400	407	4	3535	90	-	82	357	3.5	89	3.5	170
SPB 450-04	4	450	457	4	3535	90	-	82	407	-	89	7	170
SPB 500-04	4	500	507	4	3535	90	-	82	457	-	89	7	170
SPB 560-04	4	560	567	4	3535	90	-	82	517	-	89	7	170
SPB 630-04	4	630	637	4	3535	90	-	82	587	-	89	7	170
SPB 710-04	4	710	717	4	3535	90	-	82	664	3.5	89	3.5	187
SPB 800-04	4	800	807	4	4040	100	-	82	754	10	102	10	200
SPB 900-04	4	900	907	4	4040	100	-	82	854	10	102	10	216
SPB 1000-04	4	1000	1007	4	4040	100	-	82	954	10	102	16	216
SPB 1250-04	4	1250	1257	4	4545	110	-	82	1204	16	114	16	225

V-Belt Pulleys

# SPB/5 | V-Belt Pulleys For Taper Bushes



Taper Bore

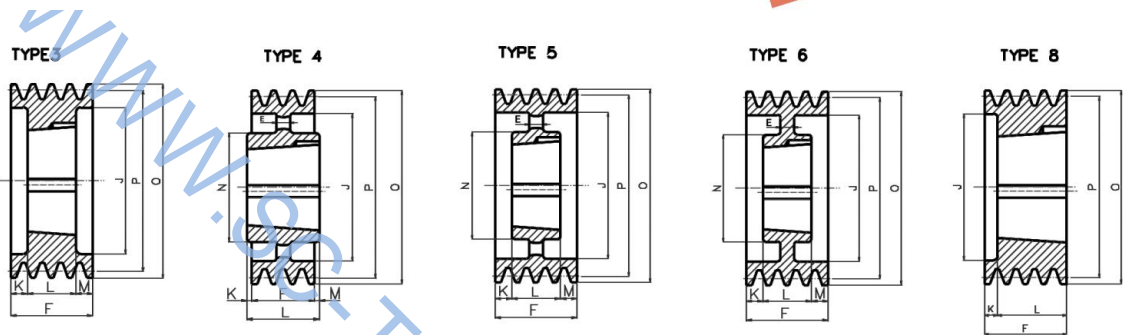

Item	Grooves	P	O	Type	Bush	Max Bore	E	F	J	K	L	M	N
SPB 125-05	5	125	132	8	2012	50	-	101	87	69	32	-	-
SPB 132-05	5	132	139	8	2517	60	-	101	94	56	45	-	-
SPB 140-05	5	140	147	3	2517	60	-	101	97	28	45	28	-
SPB 150-05	5	150	157	3	2517	60	-	101	107	28	45	28	-
SPB 160-05	5	160	167	3	2517	60	-	101	117	28	45	28	-
SPB 170-05	5	170	177	3	3020	75	-	101	127	25	51	25	-
SPB 180-05	5	180	187	3	3020	75	-	101	137	25	51	25	-
SPB 190-05	5	190	197	3	3020	75	-	101	147	25	51	25	-
SPB 200-05	5	200	207	3	3020	75	-	101	157	25	51	25	-
SPB 212-05	5	212	219	3	3020	75	-	101	169	25	51	25	-
SPB 224-05	5	224	231	3	3020	75	-	101	181	25	51	25	-
SPB 236-05	5	236	243	3	3535	90	-	101	193	6	89	6	-
SPB 250-05	5	250	257	3	3535	90	-	101	207	6	89	6	-
SPB 280-05	5	280	287	6	3535	90	25	101	237	6	89	6	170
SPB 300-05	5	300	307	6	3535	90	25	101	257	6	89	6	170
SPB 315-05	5	315	322	6	3535	90	25	101	272	6	89	6	170
SPB 335-05	5	335	342	6	3535	90	25	101	292	6	89	6	170
SPB 355-05	5	355	362	6	3535	90	17	101	312	6	89	6	170
SPB 400-05	5	400	407	5	3535	90	-	101	357	6	89	6	170
SPB 450-05	5	450	457	5	3535	90	-	101	407	-	89	12	170
SPB 500-05	5	500	507	5	3535	90	-	101	457	-	89	12	170
SPB 560-05	5	560	567	4	4040	100	-	101	517	-	102	1	200
SPB 630-05	5	630	637	4	4040	100	-	101	587	-	102	1	200
SPB 710-05	5	710	717	4	4040	100	-	101	664	0.5	102	0.5	200
SPB 800-05	5	800	807	4	4040	100	-	101	754	0.5	102	0.5	200
SPB 900-05	5	900	907	4	4040	100	-	101	854	6.5	114	6.5	200
SPB 1000-05	5	1000	1007	4	4545	110	-	101	954	6.5	114	6.5	225
SPB 1250-05	5	1250	1257	4	4545	110	-	101	1204	6.5	114	6.5	225

V-Belt Pulleys

# SPB/6 | V-Belt Pulleys For Taper Bushes



Taper Bore

TYPE 3

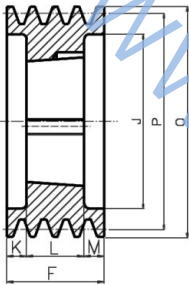

TYPE 4

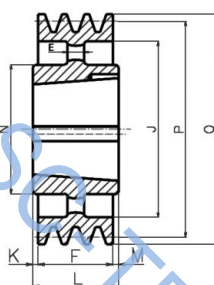

TYPE 5

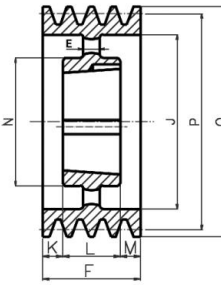

TYPE 6

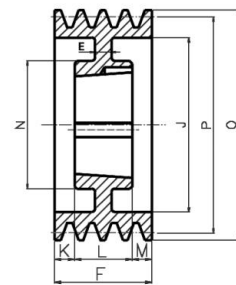

Item	Grooves	P	O	Type	Bush	Max Bore	E	F	J	K	L	M	N
SPB 140-06	6	140	147	3	2517	60	-	120	97	37.5	45	37.5	-
SPB 150-06	6	150	157	3	2517	60	-	120	107	37.5	45	37.5	-
SPB 160-06	6	160	167	3	3020	75	-	120	117	34.5	51	34.5	-
SPB 170-06	6	170	177	3	3020	75	-	120	127	34.5	51	34.5	-
SPB 180-06	6	180	187	3	3020	75	-	120	137	34.5	51	34.5	-
SPB 190-06	6	190	197	3	3020	75	-	120	147	34.5	51	34.5	-
SPB 200-06	6	200	207	3	3020	75	-	120	157	34.5	51	34.5	-
SPB 212-06	6	212	219	3	3535	90	-	120	169	15.5	89	15.5	-
SPB 224-06	6	224	231	3	3535	90	-	120	181	15.5	89	15.5	-
SPB 236-06	6	236	243	3	3535	90	-	120	193	15.5	89	15.5	-
SPB 250-06	6	250	257	3	3535	90	-	120	207	15.5	89	15.5	-
SPB 280-06	6	280	287	6	3535	90	18	120	237	15.5	89	15.5	170
SPB 300-06	6	300	307	6	3535	90	18	120	257	15.5	89	15.5	170
SPB 315-06	6	315	322	6	3535	90	18	120	272	15.5	89	15.5	170
SPB 335-06	6	335	342	6	3535	90	18	120	292	15.5	89	15.5	170
SPB 355-06	6	355	362	6	3535	90	18	120	312	15.5	89	15.5	170
SPB 400-06	6	400	407	5	3535	90	-	120	357	15.5	89	15.5	170
SPB 450-06	6	450	457	5	4040	100	-	120	407	-	102	18	200
SPB 500-06	6	500	507	5	4040	100	-	120	457	-	102	18	200
SPB 560-06	6	560	567	5	4040	100	-	120	517	-	102	18	200
SPB 630-06	6	630	637	5	4040	100	-	120	587	-	102	18	200
SPB 710-06	6	710	717	5	4040	100	-	120	664	9	102	9	216
SPB 800-06	6	800	807	5	4545	110	-	120	754	3	114	3	225
SPB 900-06	6	900	907	5	4545	110	-	120	854	3	114	3	225
SPB 1000-06	6	1000	1007	5	4545	110	-	120	954	3	114	3	225
SPB 1250-06	6	1250	1257	4	4545	110	-	120	1204	3.5	127	3.5	245

# SPB/8 | V-Belt Pulleys For Taper Bushes



Taper Bore

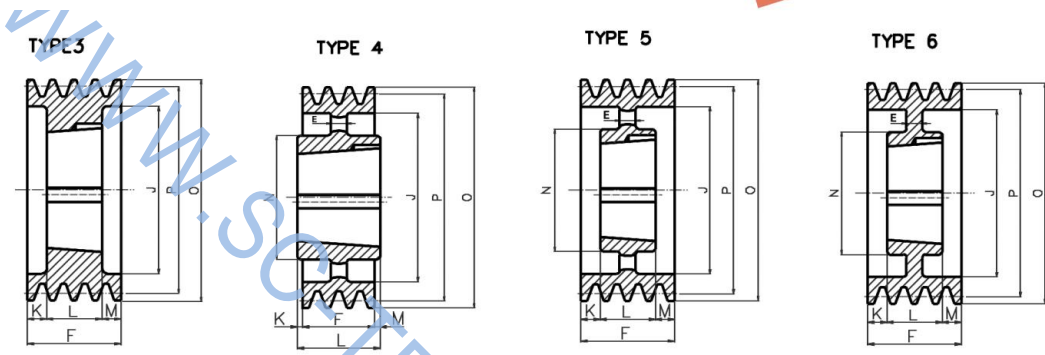

Item	Grooves	P	O	Type	Bush	Max Bore	E	F	J	K	L	M	N
SPB 140-08	8	140	147	3	2517	60	-	158	97	56.5	45	56.5	-
SPB 160-08	8	160	167	3	3020	75	-	158	117	53.5	51	53.5	-
SPB 170-08	8	170	177	3	3030	75	-	158	127	41	76	41	-
SPB 180-08	8	180	187	3	3030	75	-	158	137	41	76	41	-
SPB 190-08	8	190	197	3	3030	75	-	158	147	41	76	41	-
SPB 200-08	8	200	207	3	3535	90	-	158	157	34.5	89	34.5	-
SPB 212-08	8	212	219	3	3535	90	-	158	169	34.5	89	34.5	-
SPB 224-08	8	224	231	3	3535	90	-	158	181	34.5	89	34.5	-
SPB 236-08	8	236	243	3	3535	90	-	158	193	34.5	89	34.5	-
SPB 250-08	8	250	257	3	3535	90	-	158	207	34.5	89	34.5	-
SPB 280-08	8	280	287	3	3535	90	-	158	237	34.5	89	34.5	-
SPB 300-08	8	300	307	6	3535	90	20	158	257	34.5	89	34.5	170
SPB 315-08	8	315	322	6	3535	90	18	158	272	34.5	89	34.5	170
SPB 335-08	8	335	342	6	3535	90	18	158	292	34.5	89	34.5	170
SPB 355-08	8	355	362	6	3535	90	18	158	312	34.5	89	34.5	170
SPB 400-08	8	400	407	5	4040	100	-	158	357	28	102	28	200
SPB 450-08	8	450	457	5	4040	100	-	158	407	28	102	28	200
SPB 500-08	8	500	507	5	4040	100	-	158	457	28	102	28	200
SPB 560-08	8	560	567	5	4545	110	-	158	517	22	114	22	225
SPB 630-08	8	630	637	5	4545	110	-	158	587	22	114	22	225
SPB 710-08	8	710	717	5	4545	110	-	158	664	22	114	22	225
SPB 800-08	8	800	807	5	4545	110	-	158	754	22	114	22	225
SPB 900-08	8	900	907	5	4545	110	-	158	854	22	114	22	225
SPB 1000-08	8	1000	1007	5	5050	125	-	158	954	15.5	127	15.5	245
SPB 1250-08	8	1250	1257	5	5050	125	-	158	1204	15.5	127	15.5	245

V-Belt Pulleys

# SPB/10 | V-Belt Pulleys For Taper Bushes



Taper Bore

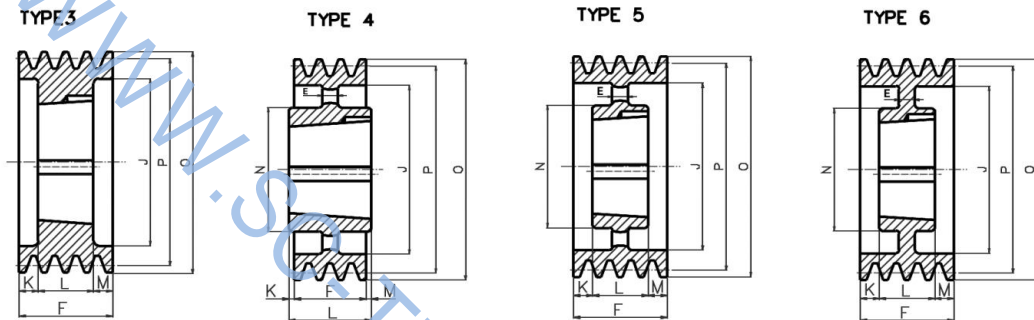

Item	Grooves	P	O	Type	Bush	Max Bore	E	F	J	K	L	M	N
SPB 224-10	10	224	231	3	3535	90	-	196	181	53.5	89	53.5	-
SPB 236-10	10	236	243	3	3535	90	-	196	193	53.5	89	53.5	-
SPB 250-10	10	250	257	3	3535	90	-	196	207	53.5	89	53.5	-
SPB 280-10	10	280	287	3	3535	90	-	196	237	53.5	89	53.5	-
SPB 315-10	10	315	322	6	3535	90	18	196	272	53.5	89	53.5	170
SPB 335-10	10	335	342	6	4040	100	20	196	292	47	102	47	200
SPB 355-10	10	355	362	6	4040	100	20	196	312	47	102	47	200
SPB 400-10	10	400	407	5	4040	100	-	196	357	47	102	47	200
SPB 450-10	10	450	457	5	4545	110	-	196	407	41	114	41	225
SPB 500-10	10	500	507	5	4545	110	-	196	457	41	114	41	225
SPB 560-10	10	560	567	5	4545	110	-	196	517	41	114	41	225
SPB 630-10	10	630	637	5	4545	110	-	196	587	41	114	41	225
SPB 710-10	10	710	717	5	4545	110	-	196	664	41	114	41	225
SPB 800-10	10	800	807	5	4545	110	-	196	754	41	114	41	225
SPB 900-10	10	900	907	5	5050	125	-	196	854	34.5	127	34.5	245
SPB 1000-10	10	1000	1007	5	5050	125	-	196	954	34.5	127	34.5	245

# SPC/3 | V-Belt Pulleys For Taper Bushes



Taper Bore

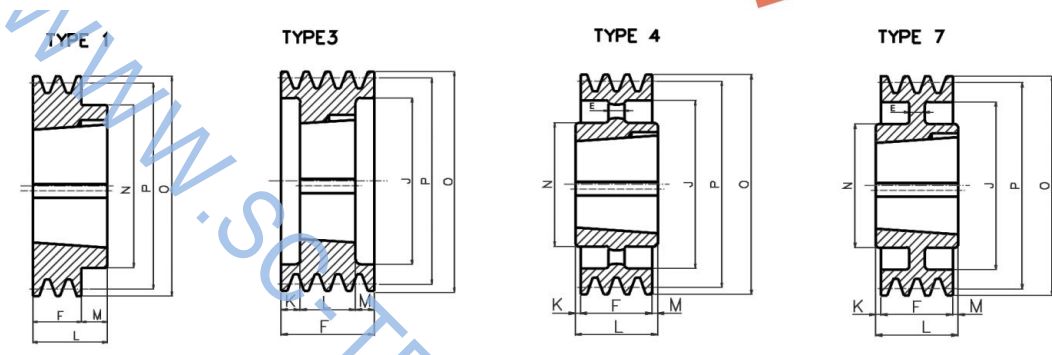

Item	Grooves	P	O	Type	Bush	Max Bore	F	J	K	L	M	N	E
SPC 200-03	3	200	209,6	3	2517	60	85	150	20	45	20	-	-
SPC 212-03	3	212	221,6	3	3020	75	85	162	17	51	17	-	-
SPC 224-03	3	224	233,6	3	3020	75	85	173	17	51	17	-	-
SPC 236-03	3	236	245,6	3	3020	75	85	185	17	51	17	-	-
SPC 250-03	3	250	259,6	3	3020	75	85	190	17	51	17	-	-
SPC 265-03	3	265	274,6	1	3535	90	85	209	-	89	4	170	-
SPC 280-03	3	280	289,6	1	3535	90	85	224	-	89	4	170	-
SPC 300-03	3	300	309,6	7	3535	90	85	249	2	89	2	170	18
SPC 315-03	3	315	324,6	7	3535	90	85	264	2	89	2	170	18
SPC 335-03	3	335	344,6	7	3535	90	85	284	2	89	2	170	18
SPC 355-03	3	355	364,6	7	3535	90	85	304	2	89	2	170	18
SPC 375-03	3	375	384,6	7	3535	90	85	324	2	89	2	170	20
SPC 400-03	3	400	409,6	4	3535	90	85	344	2	89	2	170	-
SPC 425-03	3	425	434,6	4	3535	90	85	369	2	89	2	170	-
SPC 450-03	3	450	459,6	4	3535	90	85	394	2	89	2	170	-
SPC 475-03	3	475	484,6	4	3535	90	85	419	2	89	2	170	-
SPC 500-03	3	500	509,6	4	3535	90	85	444	2	89	2	170	-
SPC 530-03	3	530	539,6	4	3535	90	85	474	2	89	2	170	-
SPC 560-03	3	560	569,6	4	3535	90	85	504	2	89	2	170	-
SPC 630-03	3	630	639,6	4	4040	100	85	574	8,5	102	8,5	200	-
SPC 800-03	3	800	809,6	4	4545	110	85	737	14,5	114	14,5	225	-
SPC 1000-03	3	1000	1009,6	4	5050	125	85	937	21	127	21	245	-
SPC 1250-03	3	1250	1259,6	4	5050	125	85	1187	21	127	21	245	-

V-Belt Pulleys



# SPC/4 | V-Belt Pulleys For Taper Bushes



Taper Bore

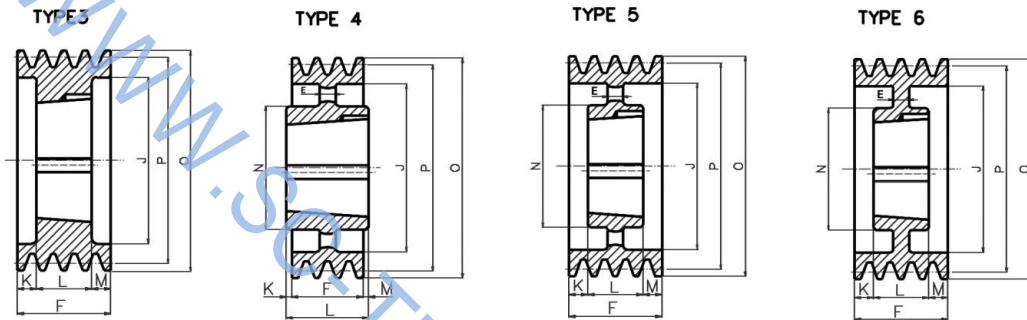

Item	Grooves	P	O	Type	Bush	Max Bore	E	F	J	K	L	M	N
SPC 200-04	4	200	209,6	3	3020	75	-	111	144	30	51	30	-
SPC 212-04	4	212	221,6	3	3020	75	-	111	156	30	51	30	-
SPC 224-04	4	224	233,6	3	3535	90	-	111	168	11	89	11	-
SPC 236-04	4	236	245,6	3	3535	90	-	111	180	11	89	11	-
SPC 250-04	4	250	259,6	3	3535	90	-	111	194	11	89	11	-
SPC 265-04	4	265	274,6	3	3535	90	-	111	209	11	89	11	-
SPC 280-04	4	280	289,6	3	3535	90	-	111	224	11	89	11	-
SPC 300-04	4	300	309,6	6	3535	90	20	111	244	11	89	11	170
SPC 315-04	4	315	324,6	6	3535	90	20	111	259	11	89	11	170
SPC 335-04	4	335	344,6	6	3535	90	20	111	279	11	89	11	170
SPC 355-04	4	355	364,6	6	3535	90	20	111	299	11	89	11	170
SPC 375-04	4	375	384,6	6	3535	90	25	111	319	11	89	11	170
SPC 400-04	4	400	409,6	5	3535	90	-	111	344	11	89	11	170
SPC 425-04	4	425	434,6	5	3535	90	-	111	369	11	89	11	170
SPC 450-04	4	450	459,6	5	3535	90	-	111	394	11	89	11	170
SPC 475-04	4	475	484,6	5	3535	90	-	111	419	11	89	11	170
SPC 500-04	4	500	509,6	5	3535	90	-	111	444	11	89	11	170
SPC 530-04	4	530	539,6	5	4040	100	-	111	474	4,5	102	4,5	170
SPC 560-04	4	560	569,6	5	4040	100	-	111	504	4,5	102	4,5	200
SPC 630-04	4	630	639,6	4	4545	110	-	111	574	1,5	114	1,5	225
SPC 710-04	4	710	719,6	4	5050	125	-	111	654	4	127	12	245
SPC 800-04	4	800	809,6	4	5050	125	-	111	737	4	127	12	245
SPC 1000-04	4	1000	1009,6	4	5050	125	-	111	937	4	127	12	245
SPC 1250-04	4	1250	1259,6	4	5050	125	-	111	1187	4	127	12	245

V-Belt Pulleys

# SPC/5 | V-Belt Pulleys For Taper Bushes



Taper Bore

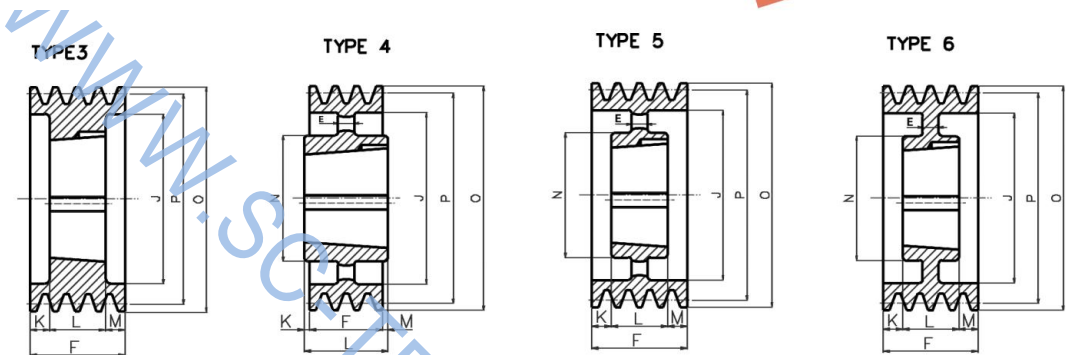

Item	Grooves	P	O	Type	Bush	Max Bore	E	F	J	K	L	M	N
SPC 200-05	5	200	209,6	3	3535	90	-	136	150	23,5	89	23,5	-
SPC 212-05	5	212	221,6	3	3535	90	-	136	160	23,5	89	23,5	-
SPC 224-05	5	224	233,6	3	3535	90	-	136	173	23,5	89	23,5	-
SPC 236-05	5	236	245,6	3	3535	90	-	136	185	23,5	89	23,5	-
SPC 250-05	5	250	259,6	3	3535	90	-	136	198	23,5	89	23,5	-
SPC 265-05	5	265	274,6	3	3535	90	-	136	213	23,5	89	23,5	-
SPC 280-05	5	280	289,6	3	3535	90	-	136	228	23,5	89	23,5	-
SPC 300-05	5	300	309,6	6	3535	90	20	136	247	23,5	89	23,5	170
SPC 315-05	5	315	324,6	6	3535	90	20	136	264	23,5	89	23,5	170
SPC 335-05	5	335	344,6	6	3535	90	20	136	280	23,5	89	23,5	170
SPC 355-05	5	355	364,6	6	3535	90	20	136	304	23,5	89	23,5	170
SPC 375-05	5	375	384,6	6	3535	90	20	136	324	23,5	89	23,5	170
SPC 400-05	5	400	409,6	5	3535	90	-	136	344	23,5	89	23,5	170
SPC 425-05	5	425	434,6	5	3535	90	-	136	369	23,5	89	23,5	170
SPC 450-05	5	450	459,6	5	4040	100	-	136	394	17	102	17	200
SPC 475-05	5	475	484,6	5	4040	100	-	136	419	17	102	17	200
SPC 500-05	5	500	509,6	5	4040	100	-	136	444	17	102	17	200
SPC 530-05	5	530	539,6	5	4545	110	-	136	474	17	102	17	200
SPC 560-05	5	560	569,6	5	4545	110	-	136	504	11	114	11	200
SPC 630-05	5	630	639,6	5	5050	125	-	136	574	4,5	127	4,5	245
SPC 710-05	5	710	719,6	5	5050	125	-	136	654	4,5	127	4,5	245
SPC 800-05	5	800	809,6	5	5050	125	-	136	737	4,5	127	4,5	245
SPC 1000-05	5	1000	1009,6	5	5050	125	-	136	937	4,5	127	4,5	245
SPC 1250-05	5	1250	1259,6	5	5050	125	-	136	1187	4,5	127	4,5	245

# SPC/6 | V-Belt Pulleys For Taper Bushes



Taper Bore

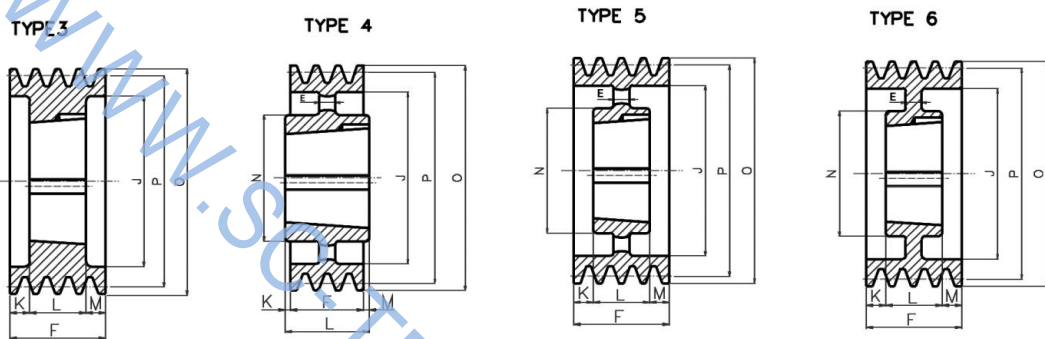

Item	Grooves	P	O	Type	Bush	Max Bore	E	F	J	K	L	M	N
SPC 200-06	6	200	209,6	3	3535	90	-	162	148	36,5	89	36,5	-
SPC 212-06	6	212	221,6	3	3535	90	-	162	160	36,5	89	36,5	-
SPC 224-06	6	224	233,6	3	3535	90	-	162	173	36,5	89	36,5	-
SPC 236-06	6	236	245,6	3	3535	90	-	162	185	36,5	89	36,5	-
SPC 250-06	6	250	259,6	3	3535	90	-	162	198	36,5	89	36,5	-
SPC 265-06	6	265	274,6	3	3535	90	-	162	213	36,5	89	36,5	-
SPC 280-06	6	280	289,6	3	3535	90	-	162	228	36,5	89	36,5	-
SPC 300-06	6	300	309,6	6	3535	90	20	162	247	36,5	89	36,5	170
SPC 315-06	6	315	324,6	6	3535	90	20	162	264	36,5	89	36,5	170
SPC 335-06	6	335	344,6	6	3535	90	20	162	280	36,5	89	36,5	170
SPC 355-06	6	355	364,6	6	3535	90	20	162	304	36,5	89	36,5	170
SPC 375-06	6	375	384,6	6	4040	100	20	162	324	30	102	30	200
SPC 400-06	6	400	409,6	6	4040	100	20	162	348	30	102	30	200
SPC 425-06	6	425	434,6	6	4040	100	30	162	369	30	102	30	225
SPC 450-06	6	450	459,6	6	4545	110	30	162	394	24	114	24	225
SPC 475-06	6	475	484,6	6	4545	110	30	162	419	24	114	24	225
SPC 500-06	6	500	509,6	5	4545	110	30	162	444	24	114	24	225
SPC 530-06	6	530	539,6	5	5050	125	30	162	474	17,5	114	17,5	245
SPC 560-06	6	560	569,6	5	5050	125	-	162	504	24	127	24	245
SPC 630-06	6	630	639,6	5	5050	125	-	162	574	17,5	127	17,5	245
SPC 710-06	6	710	719,6	5	5050	125	-	162	654	17,5	127	17,5	245
SPC 800-06	6	800	809,6	5	5050	125	-	162	737	17,5	127	17,5	245
SPC 1000-06	6	1000	1009,6	5	5050	125	-	162	937	17,5	127	17,5	245
SPC 1250-06	6	1250	1259,6	5	5050	125	-	162	1187	17,5	127	17,5	245

V-Belt Pulleys

# SPC/8 | V-Belt Pulleys For Taper Bushes



Taper Bore

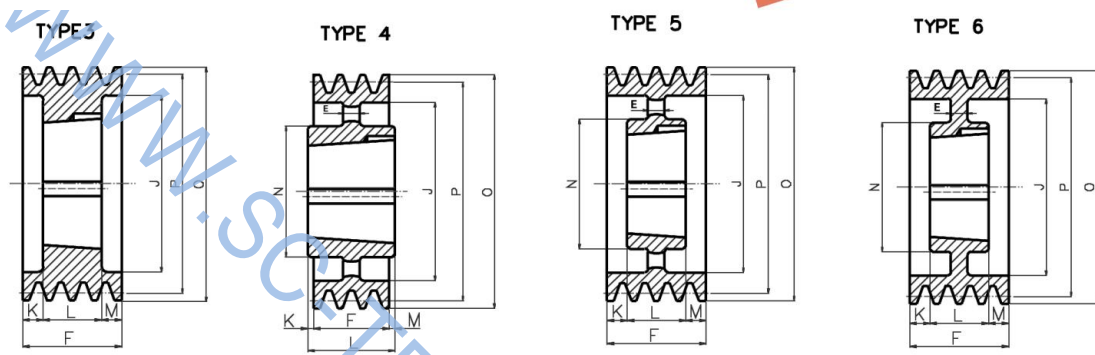

Item	Grooves	P	O	Type	Bush	Max Bore	E	F	J	K	L	M	N
SPC 200-08	8	200	209,6	3	3535	90	-	213	148	62	89	62	-
SPC 212-08	8	212	221,6	3	3535	90	-	213	160	62	89	62	-
SPC 224-08	8	224	233,6	3	3535	90	-	213	170	62	89	62	-
SPC 236-08	8	236	245,6	3	3535	90	-	213	184	62	89	62	-
SPC 250-08	8	250	259,6	3	3535	90	-	213	198	62	89	62	-
SPC 265-08	8	265	274,6	3	3535	90	-	213	213	62	89	62	-
SPC 280-08	8	280	289,6	3	3535	90	-	213	228	62	89	62	-
SPC 300-08	8	300	309,6	3	4040	100	-	213	207	55,5	102	55,5	-
SPC 315-08	8	315	324,6	3	4040	100	-	213	258	55,5	102	55,5	-
SPC 335-08	8	335	344,6	6	4040	100	-	213	280	55,5	102	55,5	-
SPC 355-08	8	355	364,6	3	4040	100	-	213	304	55,5	102	55,5	-
SPC 375-08	8	375	384,6	3	4545	110	-	213	324	49,5	114	49,5	-
SPC 400-08	8	400	409,6	6	4545	110	20	213	348	49,5	114	49,5	220
SPC 425-08	8	425	434,6	6	4545	110	30	213	369	49,5	114	49,5	245
SPC 450-08	8	450	459,6	6	5050	125	30	213	394	43	127	43	245
SPC 475-08	8	475	484,6	6	5050	125	30	213	419	43	127	43	245
SPC 500-08	8	500	509,6	6	5050	125	30	213	444	43	127	43	245
SPC 530-08	8	530	539,6	6	5050	125	30	213	474	43	127	43	245
SPC 560-08	8	560	569,6	5	5050	125	-	213	504	43	127	43	245
SPC 630-08	8	630	639,6	5	5050	125	-	213	574	43	127	43	245
SPC 710-08	8	710	719,6	5	5050	125	-	213	656	43	127	43	245
SPC 800-08	8	800	809,6	5	5050	125	-	213	737	43	127	43	245
SPC 1000-08	8	1000	1009,6	5	5050	125	-	213	937	43	127	43	245
SPC 1250-08	8	1250	1259,6	5	5050	125	-	213	1187	43	127	43	245

# SPC/10 | V-Belt Pulleys For Taper Bushes



Taper Bore

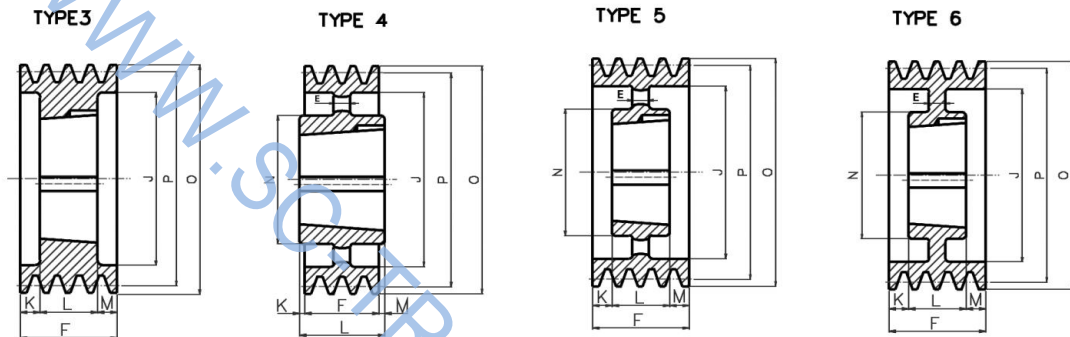

Item	Grooves	P	O	Type	Bush	Max Bore	E	F	J	K	L	M	N
SPC 250-10	10	250	259,6	3	4040	100	-	264	96	81	102	81	-
SPC 280-10	10	280	289,6	3	4040	100	-	264	226	81	102	81	-
SPC 300-10	10	300	309,6	3	4545	110	-	264	245	75	114	75	-
SPC 315-10	10	315	324,6	3	4545	110	-	264	258	75	114	75	-
SPC 355-10	10	355	364,6	3	4545	110	-	264	299	75	114	75	-
SPC 400-10	10	400	409,6	3	5050	125	-	264	342	68,5	127	68,5	245
SPC 450-10	10	450	459,6	6	5050	125	40	264	394	68,5	127	68,5	245
SPC 500-10	10	500	509,6	6	5050	125	40	264	444	68,5	127	68,5	245
SPC 560-10	10	560	569,6	5	5050	125	-	264	504	68,5	127	68,5	245
SPC 630-10	10	630	639,6	5	5050	125	-	264	574	68,5	127	68,5	245
SPC 710-10	10	710	719,6	5	5050	125	-	264	654	68,5	127	68,5	245
SPC 800-10	10	800	809,6	5	5050	125	-	264	737	68,5	127	68,5	245
SPC 1000-10	10	1000	1009,6	5	5050	125	-	264	937	68,5	127	68,5	245
SPC 1250-10	10	1250	1259,6	5	5050	125	-	264	1187	68,5	127	68,5	245

# V-Belt Pulleys with Solid Hub



TYPE 1

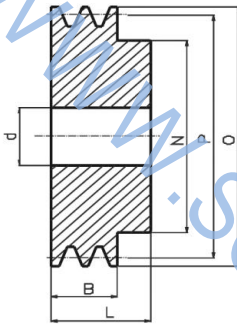

TYPE 2

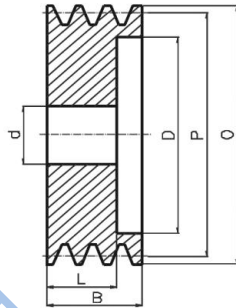

TYPE 3

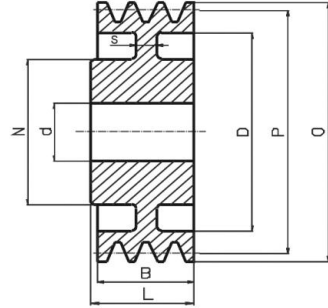

TYPE 4

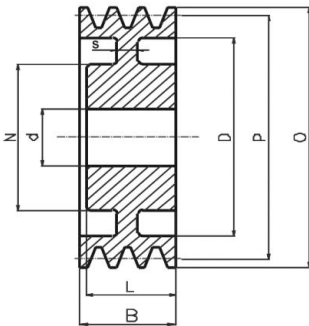

TYPE 5

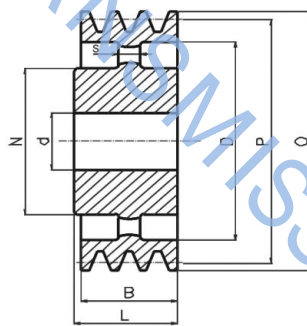

TYPE 6

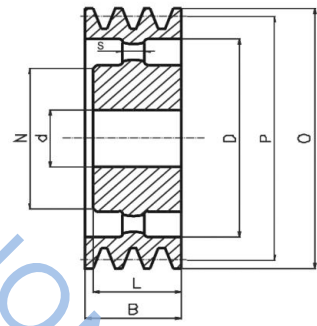

TYPE 7

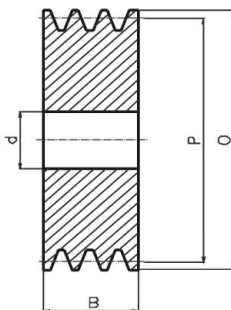

TYPE 8

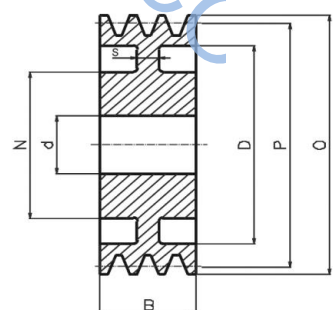

# SPZ | V-Belt Pulleys with Solid Hub



WWW.SCI-TRANSMISSION.COM

Description	P	O	Grooves	N	L	D	S	B	Type	d
SPZ50	50	54	1	40	28			16	1	10
			2	40	35			28	1	10
			3					40	7	10
SPZ56	56	60	1	45	28			16	1	10
			2	45	35			28	1	10
			3					40	7	10
SPZ63	63	67	1	50	28			16	1	10
			2	50	35			28	1	10
			3					40	7	10
SPZ71	71	75	1	50	28			16	1	10
			2	55	35			28	1	10
			3					40	7	10
SPZ75	75	79	1	50	28			16	1	10
			2	60	35			28	1	10
			3					40	7	10
SPZ80	80	84	1	50	28			16	1	10
			2	60	35			28	1	10
			3					40	7	10
SPZ85	85	89	1	50	28			16	1	10
			2	60	35			28	1	10
			3					40	7	15
SPZ90	90	94	1	50	28			16	1	10
			2	60	35			28	1	10
			3					40	7	15
SPZ95	95	99	1	50	28			16	1	10
			2	60	35			28	1	15
			3					40	7	15
SPZ100	100	104	1	50	28			16	1	10
			2	60	35			28	1	15
			3					40	7	15
SPZ106	106	110	1	50	28			16	1	10
			2	60	35			28	1	15
			3					40	7	15
SPZ112	112	116	1	50	28			16	1	10
			2	60	35			28	1	15
			3					40	7	15
SPZ118	118	122	1	50	28	93	8	16	3	10
			2	60	35			28	3	15
			3					40	7	15
SPZ125	125	129	1	50	28	100	8	16	3	15
			2	60	35			28	3	15
			3					40	7	15

V-Belt Pulleys

# SPZ | V-Belt Pulleys with Solid Hub



WWW.SC

V-Belt Pulleys

Description	P	O	Grooves	N	L	D	S	B	Type	d
SPZ132	132	136	1	50	28	106	8	16	3	15
			2	60	40	105	8	28	3	15
			3	60	40	106	8	40	8	15
SPZ140	140	144	1	50	28	114	8	16	3	15
			2	60	40	114	8	28	3	15
			3	60	40	114	8	40	8	15
SPZ150	150	154	1	50	28	124	8	16	3	15
			2	60	40	124	8	28	3	15
			3	60	40	124	8	40	8	20
SPZ160	160	164	1	55	32	134	8	16	3	15
			2	60	40	134	8	28	3	15
			3	65	45	134	8	40	8	20
SPZ180	180	184	1	55	32	154	8	16	5	20
			2	60	40	154	8	28	5	20
			3	65	45	154	8	40	5	20
SPZ200	200	204	1	55	32	174	8	16	5	20
			2	60	40	174	8	28	5	20
			3	65	45	174	10	40	5	20
SPZ224	224	228	1	55	32	198	8	16	5	20
			2	60	40	198	8	28	5	20
			3	65	45	198	10	40	5	20
SPZ250	250	254	1	55	32	224	8	16	5	20
			2	60	40	224	10	28	5	20
			3	65	45	224	12	40	5	20
SPZ280	280	284	2	65	45	254	12	28	5	20
SPZ315	315	319	2	65	45	289	12	28	5	20



# SPA | V-Belt Pulleys with Solid Hub



Description	P	O	Grooves	N	L	D	S	B	Type	d
SPA40	40	45.5	1	40	35			20	1	10
SPA50	50	55.5	1	40	35			20	1	10
			2	40	45			35	1	10
SPA60	60	65.5	1	40	35			20	1	10
			2	40	45			35	1	10
			3					50	7	10
SPA71	71	76.5	1	40	40			20	1	10
			2	50	45			35	1	10
			3	52	52			50	1	10
SPA75	75	80.5	1	40	40			20	1	10
			2	50	45			35	1	10
			3					50	7	10
			4					65	7	10
			5					80	7	10
SPA80	80	85.5	1	45	40			20	1	10
			2	50	45			35	1	10
			3					50	7	15
			4					65	7	15
			5					80	7	15
SPA85	85	90.5	1	45	40			20	1	10
			2	50	45			35	1	10
			3					50	7	15
			4					65	7	15
			5					80	7	15
SPA90	90	95.5	1	45	40			20	1	10
			2	60	45			35	1	15
			3					50	7	15
			4					65	7	15
			5					80	7	15
SPA95	95	100.5	1	45	40			20	1	10
			2	60	45			35	1	15
			3					50	7	15
			4					65	7	15
			5					80	7	15
SPA100	100	105.5	1	48	40			20	1	10
			2	60	45			35	1	15
			3					50	7	15
			4		52	67		65	7	15
			5		52	67		80	7	15
SPA106	106	111.5	1	48	40			20	1	10
			2	60	45			35	1	15
SPA112	112	117.5	1	48	40			20	1	10
			2	60	45			35	1	15
			3					50	7	15
			4		52	79		65	2	15
			5		52	79		80	2	15
SPA118	118	123.5	1	60	40			20	1	15
			2	60	45			35	1	15
			3					50	7	15
			4		52	87		65	2	15
			5		52	87		80	2	15

# SPA | V-Belt Pulleys with Solid Hub



Description	P	O	Grooves	N	L	D	S	B	Type	d
SPA132	132	137.5	1	60	40	97	97	20	1	15
			2	60	45			35	1	15
			3					50	7	15
			4		52			65	2	15
			5		52			80	2	15
SPA140	140	145.5	1	60	40	107	10	20	3	15
			2	60	45	107	10	35	3	15
			3	65	52	107	12	50	3	15
			4		52	107		65	2	20
			5		52	107		80	2	20
SPA150	150	155.5	1	60	40	117	10	20	3	15
			2	60	45	117	10	35	3	15
			3	65	52	117	12	50	3	20
			4		52	117		65	2	20
			5		52	117		80	2	20
SPA160	160	165.5	1	60	40	127	10	20	3	15
			2	60	45	127	10	35	3	15
			3	70	52	127	12	50	3	20
			4	70	52	127	18	65	4	20
			5	80	52	127	18	80	4	20
SPA170	170	175.5	1	60	40	137	10	20	3	15
			2	60	45	137	10	35	3	15
			3	70	52	137	12	50	3	20
			4	80	52	137	18	65	4	20
			5	80	52	137	18	80	4	20
SPA180	180	185.5	1	65	40	147	12	20	3	20
			2	70	50	147	12	35	3	20
			3	70	52	147	12	50	3	20
			4	80	60	147	18	65	4	20
			5	80	65	147	18	80	4	20
SPA200	200	205.5	1	65	45	167	12	20	3	20
			2	70	50	167	12	35	3	20
			3	70	52	167	12	50	3	20
			4	80	60	167	18	65	4	20
			5	80	65	167	18	80	4	20
SPA224	224	229.5	1	65	45	192	12	20	3	20
			2	70	50	192	12	35	3	20
			3	80	52	192	12	50	3	20
			4	90	60	192	18	65	4	20
			5	90	65	192	18	80	4	20
SPA250	250	255.5	1	75	45	217	12	20	3	20
			2	75	50	217	12	35	3	20
			3	80	60	217	12	50	3	20
			4	90	65	217	18	65	3	20
			5	90	65	217	18	80	4	20
SPA280	280	285.5	1	75	45	247	14	20	5	20
			2	80	50	247	14	35	5	20
			3	80	60	247	14	50	5	20
			4	90	65	247	14	65	5	20
			5	100	65	247	14	80	6	25

# SPA | V-Belt Pulleys with Solid Hub



Description	P	O	Grooves	N	L	D	S	B	Type	d
SPA300	300	305.5	1	75	50	267	14	20	5	20
			2	80	50	267	14	35	5	20
			3	80	60	267	14	50	5	20
			4	90	65	267	14	65	5	20
			5	100	65	267	14	80	6	25
SPA315	315	320.5	1	75	50	282	14	20	5	20
			2	80	50	282	14	35	5	20
			3	90	60	282	14	50	5	20
			4	90	65	282	14	65	5	20
			5	100	65	282	16	80	6	25
SPA355	355	360.5	1	75	50	322	14	20	5	20
			2	80	50	322	14	35	5	20
			3	90	60	322	14	50	5	20
			4	90	65	322	16	65	5	25
			5	100	65	322	18	80	6	25
SPA400	400	405.5	1	90	50	367	14	20	5	20
			2	90	50	367	14	35	5	20
			3	100	60	367	16	50	5	25
			4	100	65	367	20	65	5	25
			5	100	65	367	22	80	6	25
SPA450	450	455.5	1	90	50	417	14	20	5	20
			2	100	50	417	14	35	5	25
			3	100	60	417	16	50	5	25
			4	105	65	417	20	65	6	25
			5	105	65	417	22	80	6	25
SPA500	500	505.5	1	90	50	467	14	20	5	20
			2	100	50	467	16	35	5	25
			3	105	60	467	20	50	5	25
			4	105	65	467	20	65	6	25
			5	110	65	467	22	80	6	25
SPA560	560	565.5	1	100	50	527	15	20	5	25
			2	100	50	527	20	35	5	25
			3	120	65	527	20	50	5	25
			4	120	65	527	20	65	5	25
			5	120	80	527	24	80	5	25
			6	120	80	527	26	95	6	25
SPA600	600	605.5	1	100	50	567	16	20	5	25
			2	110	50	567	20	35	5	25
			3	120	65	567	20	50	5	25
			4	120	80	567	24	65	5	25
			5	120	80	567	24	80	5	25
			6	120	80	567	26	95	6	25
SPA630	630	635.5	1	100	50	597	16	20	5	25
			2	110	50	597	20	35	5	25
			3	120	65	597	20	50	5	25
			4	120	80	597	20	65	5	25
			5	120	80	597	24	80	5	25
			6	120	80	597	26	95	6	25

# SPB | V-Belt Pulleys with Solid Hub



Description	P	O	Grooves	N	L	D	S	B	Type	d
SPB70	70	77	1	45	45			25	1	10
			2	45	48			44	1	10
SPB80	80	87	1	50	45			25	1	10
			2	50	48			44	1	10
			3					63	7	15
			4					82	7	15
			5					101	7	15
SPB90	90	97	1	50	45			25	1	10
			2	50	49			44	1	10
			3					63	7	15
			4					82	7	15
			5					101	7	15
SPB100	100	107	1	52	45			25	1	10
			2	55	55			44	1	15
			3					63	7	15
			4					82	7	15
			5					101	7	15
SPB112	112	119	1	55	45			25	1	15
			2	60	55			44	1	15
			3					63	7	15
			4					82	7	20
			5					101	7	20
SPB120	120	127	1	55	45			25	1	15
			2	60	55			44	1	15
			3					63	7	15
			4					82	7	20
			5					101	7	20
			6					120	7	20
SPB125	125	132	1	58	45			25	1	15
			2	60	55			44	1	15
			3		60			83	2	15
			4		60			83	2	20
			5		60			83	2	20
			6		60			83	2	20
SPB132	132	139	1	60	45			25	1	15
			2	60	55			44	1	15
			3		60			88	2	15
			4		60			88	2	20
			5		60			88	2	20
			6		60			88	2	20
SPB140	140	147	1	65	45			25	1	20
			2	65	55			44	1	20
			3		60			98	2	20
			4		60			98	2	20
			5		60			98	2	20
			6		60			98	2	20
SPB150	150	157	1	65	45			25	1	20
			2	65	55			44	1	20
			3		60			108	2	20
			4		60			108	2	20
			5		60			108	2	20
			6		60			108	2	20

# SPB | V-Belt Pulleys with Solid Hub



Description	P	O	Grooves	N	L	D	S	B	Type	d
SPB160	160	167	1	65	45	118	12	25	3	20
			2	70	55	118	12	44	3	20
			3		60	118		63	2	20
			4		60	118		82	2	20
			5		60	118		101	2	20
			6		65	118		120	2	20
SPB170	170	177	1	65	45	128	12	25	3	20
			2	70	55	128	12	44	3	20
			3	70	60	128		63	4	20
			4		60	128		82	4	20
			5		60	128		101	4	20
			6		65	128		120	4	20
SPB180	180	187	1	65	45	138	12	25	3	20
			2	70	55	138	12	44	3	20
			3	80	60	138	18	63	4	20
			4		60	138		82	4	20
			5		70	138		101	4	20
			6		70	138		120	4	20
SPB200	200	207	1	70	45	158	14	25	3	20
			2	70	55	158	14	44	3	20
			3	80	60	158	18	63	4	20
			4	88	60	158	25	82	4	20
			5	96	70	158		101	4	25
			6	96	70	158		120	4	25
SPB212	212	219	1	70	45	170	14	25	3	20
			2	77	55	170	14	44	3	20
			3	80	60	170	18	63	4	20
			4	88	60	170	25	82	4	20
			5	96	70	170	25	101	4	25
			6	104	80	170	25	120	4	25
SPB225	225	232	1	70	45	183	14	25	3	20
			2	77	55	183	14	44	3	20
			3	80	60	183	18	63	4	20
			4	88	60	183	25	82	4	20
			5	96	70	183	25	101	4	25
			6	104	80	183	25	120	4	25
SPB250	250	257	1	70	50	208	14	25	3	20
			2	77	55	208	14	44	3	20
			3	80	60	208	18	63	4	20
			4	96	70	208	25	82	4	25
			5	104	75	208	25	101	4	25
			6	104	80	208	25	120	4	25
SPB280	280	287	1	76	50	238	14	25	3	20
			2	80	55	238	14	44	3	20
			3	90	60	238	18	63	4	20
			4	96	65	238	25	82	4	25
			5	104	75	238	25	101	4	25
			6	104	80	238	25	120	4	25
SPB300	300	307	1	76	50	258	15	25	5	20
			2	80	55	258	15	44	5	20
			3	90	60	258	18	63	6	20
			4	96	65	258	20	82	6	25
			5	104	75	258	22	101	6	25
			6	104	80	258	24	120	6	25

# SPB | V-Belt Pulleys with Solid Hub



Description	P	O	Grooves	N	L	D	S	B	Type	d
SPB315	315	322	1	76	50	273	15	25	5	20
			2	88	60	273	15	44	5	20
			3	90	60	273	18	63	6	20
			4	96	65	273	20	82	6	25
			5	104	75	273	22	101	6	25
			6	120	90	273	25	120	6	25
SPB355	355	362	1	80	50	313	15	25	5	20
			2	88	60	313	15	44	5	20
			3	92	60	313	18	63	6	25
			4	96	65	313	20	82	6	25
			5	104	75	313	22	101	6	25
			6	120	90	313	25	120	6	25
SPB400	400	407	1	85	55	358	18	25	5	20
			2	93	60	358	18	44	5	20
			3	96	65	358	22	63	5	25
			4	104	75	358	24	82	6	25
			5	112	85	358	24	101	6	25
			6	120	100	358	28	120	6	25
SPB450	450	457	1	90	60	408	18	25	5	20
			2	90	60	408	18	44	5	20
			3	96	65	408	22	63	5	25
			4	104	75	408	24	82	6	25
			5	112	85	408	26	101	6	25
			6	120	100	408	28	120	6	25
SPB500	500	507	1	100	60	458	18	25	5	25
			2	100	65	458	20	44	5	25
			3	104	75	458	24	63	5	25
			4	112	85	458	28	82	5	25
			5	120	90	458	30	101	6	25
			6	129	105	458	33	120	6	25
SPB560	560	567	1	100	60	518	18	25	5	25
			2	100	65	518	20	44	5	25
			3	104	75	518	24	63	5	25
			4	112	85	518	28	82	5	25
			5	120	90	518	30	101	6	25
			6	129	105	518	33	120	6	25
SPB600	600	607	1	100	60	558	18	25	5	25
			2	100	65	558	20	44	5	25
			3	104	75	558	24	63	5	25
			4	115	85	558	28	82	5	25
			5	120	90	558	30	101	6	25
			6	129	105	558	33	120	6	25
SPB630	630	637	1	100	60	588	18	25	5	25
			2	100	65	588	20	44	5	25
			3	105	75	588	24	63	5	25
			4	120	85	588	28	82	5	25
			5	128	90	588	30	101	6	25
			6	140	105	588	33	120	6	25

# SPC | V-Belt Pulleys with Solid Hub



Description	P	O	Grooves	N	L	D	S	B	Type	d
SPC100	100	109.6	1	60	50			34	1	15
SPC120	120	129.6	1	65	50			34	1	15
			2					59.5	7	15
SPC140	140	149.6	1	70	50			34	1	20
			2					59.5	7	20
			3					85	2	20
			4					110.5	2	20
SPC150	150	159.6	1	70	50			34	1	20
			2					59.5	7	20
			3					85	2	20
			4					110.5	2	20
			5					136	2	20
SPC160	160	169.6	1	72	50			34	1	20
			2					59.5	7	20
			3					85	2	20
			4					110.5	2	20
			5					136	2	20
			6					161.5	2	20
SPC180	180	189.6	1	76	50	123	16	34	3	20
			2	80	60	123	16	59.5	8	20
			3	82	65	123	18	85	4	20
			4	82	80	123	20	110.5	4	20
			5	82	96	123	20	136	4	20
			6	82	96	123	25	161.5	4	20
SPC200	200	209.6	1	76	50	143	16	34	3	20
			2	80	60	143	16	59.5	3	20
			3	86	65	143	18	85	4	20
			4	90	90	143	25	110.5	4	20
			5	90	100	143	25	136	4	25
			6	90	100	143	25	161.5	4	25
SPC225	225	234.6	1	86	50	168	16	34	3	20
			2	88	60	168	18	59.5	3	20
			3	90	70	168	21	85	4	20
			4	90	90	168	25	110.5	4	25
			5	90	100	168	25	136	4	25
			6	90	100	168	25	161.5	4	25
SPC250	250	259.6	1	86	50	193	16	34	3	20
			2	92	60	193	18	59.5	3	20
			3	92	70	193	21	85	4	20
			4	100	90	193	25	110.5	4	25
			5	102	100	193	25	136	4	25
			6	102	100	193	25	161.5	4	25
SPC280	280	289.6	1	86	50	223	16	34	3	20
			2	92	60	223	18	59.5	3	20
			3	92	70	223	21	85	4	20
			4	100	90	223	25	110.5	4	25
			5	102	100	223	25	136	4	25
			6	102	100	223	25	161.5	4	25
SPC300	300	309.6	1	86	50	243	16	34	3	20
			2	92	60	243	18	59.5	3	20
			3	92	70	243	21	85	4	20
			4	100	90	243	25	110.5	4	25
			5	104	100	243	25	136	4	25
			6	104	100	243	25	161.5	4	25

# SPC | V-Belt Pulleys with Solid Hub



www.sctparts.com

Description	P	O	Grooves	N	L	D	S	B	Type	d
SPC315	315	324.6	1	92	50	258	16	34	5	20
			2	92	60	258	18	59.5	5	20
			3	92	70	258	22	85	6	25
			4	110	90	258	25	110.5	4	25
			5	112	100	258	25	136	4	25
			6	112	100	258	28	161.5	4	25
SPC340	340	349.6	1	100	50	283	16	34	5	20
			2	100	60	283	18	59.5	5	20
			3	100	70	283	22	85	6	25
			4	114	90	283	25	110.5	6	25
			5	114	100	283	28	136	6	25
			6	114	100	283	30	161.5	6	25
SPC355	355	364.6	1	110	50	298	16	34	5	20
			2	110	60	298	18	59.5	5	20
			3	110	70	298	22	85	6	25
			4	114	90	298	25	110.5	6	25
			5	114	100	298	28	136	6	25
			6	114	100	298	30	161.5	6	25
SPC400	400	409.6	1	110	60	343	18	34	5	25
			2	110	70	343	20	59.5	5	25
			3	114	90	343	24	85	5	25
			4	120	90	343	26	110.5	6	25
			5	120	100	343	28	136	6	25
			6	120	100	343	30	161.5	6	25
SPC450	450	459.6	1	110	60	393	18	34	5	25
			2	110	70	393	20	59.5	5	25
			3	114	90	393	24	85	5	25
			4	120	90	393	26	110.5	6	25
			5	120	100	393	30	136	6	25
			6	120	100	393	32	161.5	6	25
SPC500	500	509.6	1	114	60	443	18	34	5	25
			2	114	70	443	20	59.5	5	25
			3	114	90	443	24	85	5	25
			4	126	100	443	28	110.5	6	25
			5	126	100	443	30	136	6	25
			6	126	100	443	32	161.5	6	25
SPC560	560	569.6	1	114	60	503	20	34	5	25
			2	114	70	503	24	59.5	5	25
			3	114	90	503	28	85	5	25
			4	130	100	503	30	110.5	6	25
			5	130	100	503	32	136	6	25
			6	130	100	503	35	161.5	6	25
SPC600	600	609.6	1	114	60	543	20	34	5	25
			2	114	70	543	24	59.5	5	25
			3	114	90	543	28	85	5	25
			4	130	100	543	30	110.5	6	25
			5	130	100	543	32	136	6	25
			6	130	100	543	35	161.5	6	25
SPC630	630	639.6	1	114	60	573	20	34	5	25
			2	114	70	573	24	59.5	5	25
			3	114	90	573	28	85	5	25
			4	130	100	573	30	110.5	6	25
			5	130	100	573	32	136	6	25
			6	130	100	573	35	161.5	6	25

V-Belt Pulleys



# Adjustable Speed V-Belt Pulleys

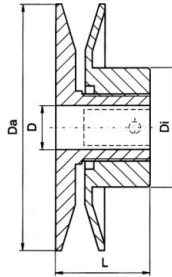

**TYPE 1**

1 groove can also be supplied bored for Taper Bushes.\*

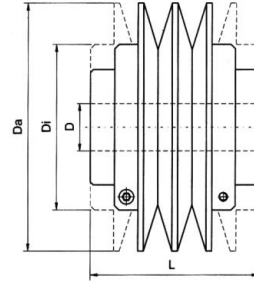

**TYPE 2**

**Material:GG20-25**

Description	Profile	Type	Pitch Dia.		Di	Da	L	Pilot bore	Bore	Weight Kg
			Min.	Max.						
S092-1	10X6	1	55	68						
*1008	SPZ	1	60	89	48	92	31	10	28	0.85
S093-1	10X6	1	54	78						
	13X8	1	55	85	48	93	35	10	24	0.90
S108-1	10X6	1	68	92						
*1108	13X8	1	70	100						
	SPZ	1	75	93	63	108	35	10	28	1.20
	SPA	1	76	102						
S120-1	10X6	1	80	104						
*1108	13X8	1	82	112						
	SPZ	1	87	105	75	120	35	12	28	1.50
	SPA	1	88	114						
S138-1	10X6	1	98	122						
*1108	13X6	1	100	130						
	SPZ	1	105	123	93	138	38	16	42	2.20
	SPA	1	106	132						
S159-1	10X8	1	122	152						
*1615	SPA	1	128	154	115	159	39	18	48	3.50
S180-1	10X8	1	128	158						
*1615	17X11	1	132	170						
	SPA	1	134	160	121	180	45	18	48	4.20
	SPB	1	137	173						
S120-2	10X6	2	80	104						
	13X8	2	82	112						
	SPZ	2	87	105	75	120	68	18	28	2.95
	SPA	2	88	114						
S138-2	10X6	2	98	122						
	13X8	2	100	130						
	SPZ	2	105	123	93	138	74	18	42	4.32
	SPA	2	106	132						
S159-2	13X8	2	122	152						
	SPA	2	128	154	115	159	76	18	48	5.90
S180-2	13X8	2	128	158						
	17X11	2	132	170						
	SPA	2	134	160	121	180	88	18	48	8.40
	SPB	2	137	173						
S200-2	13X8	2	149	177						
	17X11	2	152	190						
	SPA	2	155	179	141	200	93	22	48	10.90
	SPB	2	159	193						
S250-2	13X8	2	199	227						
	17X11	2	202	240						
	22X14	2	204	236						
	SPA	2	205	229	191	250	93	22	65	16.65
	SPB	2	209	243						
	SPC	2	216	240						

# Flat Belt Pulleys For Taper Bushes



Flat Belt Pulleys from stock are statically balanced to grade G6.3 and from 355mm dynamically balanced to grade G6.3. Pulleys smaller than 355mm dynamically balancing can be supplied to order.

**Taper Bore**

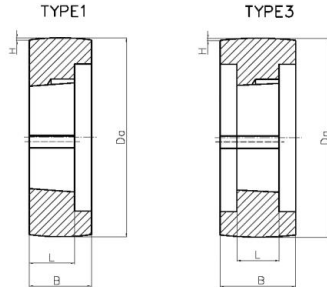

Part No.	Da	B	Bush No.	L	Type	H	Speed	Weight without bush
FL063050	63	50	1108	22	3	0.3	12000	0.6
FL080050	80	50	1210	25	1	0.3	9500	1.2
FL080080	80	80	1615	38	1	0.3	9500	1.5
FL090050	90	50	1615	38	1	0.3	8500	1.5
FL090080	80	80	1615	38	1	0.3	8500	1.9
FL090100	100	100	1615	38	3	0.3	8500	2.2
FL100050	100	50	1615	38	1	0.3	7500	1.8
FL100080	80	80	1615	38	1	0.3	7500	2.4
FL100100	100	100	1615	38	3	0.3	7500	2.7
FL125050	125	50	2012	32	1	0.4	6000	2.6
FL125080	80	80	2517	45	1	0.4	6000	3.4
FL125100	100	100	2517	45	3	0.4	6000	3.8
FL125125	125	125	2517	45	3	0.4	6000	4.5
FL140050	140	50	2012	32	1	0.4	5400	3.4
FL140080	80	80	2517	45	1	0.4	5400	4.5
FL140100	100	100	3020	51	1	0.4	5400	4.9
FL140125	125	125	3030	76	1	0.4	5400	5.2
FL150050	150	50	2012	32	1	0.4	5000	4.0
FL150080	80	80	2517	45	1	0.4	5000	5.4
FL150100	100	100	3020	51	1	0.4	5000	6.2
FL150125	125	125	3030	76	1	0.4	5000	6.7
FL150160	160	160	3030	76	1	0.4	5000	7.6
FL160050	160	50	2012	32	1	0.5	4750	4.6
FL160080	80	80	2517	45	1	0.5	4750	6.3
FL160100	100	100	3020	51	1	0.5	4750	7.5
FL160125	125	125	3030	76	1	0.5	4750	8.5
FL160160	160	160	3030	76	1	0.5	4750	10.0
FL180080	180	80	2517	45	1	0.5	4250	7.2
FL180100	100	100	3020	51	1	0.5	4250	9.8
FL180125	125	125	3030	76	1	0.5	4250	12.0
FL180160	160	160	3030	76	1	0.5	4250	14.0
FL200080	200	80	2517	45	1	0.6	3800	8.0
FL200100	100	100	3020	51	1	0.6	3800	12.0
FL200125	125	125	3030	76	1	0.6	3800	15.5
FL200160	160	160	3030	76	1	0.6	3800	18.0
FL224080	224	80	2517	45	1	0.6	3400	8.2
FL224100	100	100	3020	51	1	0.6	3400	11.5
FL224125	125	125	3030	76	1	0.6	3400	15.0
FL224160	160	160	3030	76	1	0.6	3400	17.0
FL250080	250	80	2517	45	1	0.8	3000	8.5
FL250100	100	100	3020	51	1	0.8	3000	11.0
FL250125	125	125	3030	76	1	0.8	3000	15.5
FL250160	160	160	3030	76	1	0.8	3000	17.5
FL280100	280	100	3020	51	1	0.8	2700	13.4
FL280125	125	125	3030	76	1	0.8	2700	17.3
FL280160	160	160	3535	89	1	0.8	2700	21.8
FL280200	200	200	4040	102	1	0.8	2700	28.3
FL315100	315	100	3020	51	1	0.8	2400	15.8
FL315125	125	125	3030	76	1	0.8	2400	19.0
FL315160	160	160	3535	89	1	0.8	2400	26.0
FL315200	200	200	4040	102	1	0.8	2400	32.0
FL355100	355	100	3030	76	1	0.8	2150	20.0
FL355125	125	125	3030	76	1	0.8	2150	22.0
FL355160	160	160	3535	89	1	0.8	2150	27.0
FL355200	200	200	4040	102	1	0.8	2150	36.0
FL400100	400	100	3535	89	1	1.0	1900	26.0
FL400125	125	125	3535	89	1	1.0	1900	28.0
FL400160	160	160	3535	89	1	1.0	1900	32.0
FL400200	200	200	4040	102	1	1.0	1900	40.0
FL450160	450	160	3535	89	1	1.0	1700	42.5
FL450200	200	200	4040	102	3	1.0	1700	54.5
FL500160	500	160	4040	102	3	1.0	1500	53.5
FL500200	200	200	4545	115	3	1.0	1500	69.0
FL560160	560	160	4040	102	3	1.2	1350	66.5
FL560200	200	200	4545	115	3	1.2	1350	86.0
FL630160	630	160	4545	115	3	1.2	1200	80.0
FL630200	200	200	5050	127	3	1.2	1200	103.0